



**INSTALLATION INSTRUCTIONS**  
**CFMOTO UFORCE 1000**  
**REAR WINDSHIELD WITH TINTED VENT**  
**PART # 77-3000V-R**

**IMPORTANT NOTICES**

**READ AND UNDERSTAND THESE INSTRUCTIONS COMPLETELY BEFORE INSTALLATION TO AVOID INJURY TO YOURSELF, DAMAGE TO THE VEHICLE OR ACCESSORY.**

- For proper installation, **TWO** people are required.
- Torque specifications must be followed when tightening bolts. **Over-tightening any and/or all screws will cause cracks around mounting holes which is not covered by any warranty.**
  - As specified on carton label, once protective film on shields is removed, product cannot be returned.
- As specified on carton label, damage caused by packaging staples is not covered by warranty. All staples must be removed prior to removing product from carton.
- Failure to follow these installation instructions completely may void any warrantable components and result in product damage or personal injury.
- Do not use Loctite or any other similar fastener adhesive. These types of products react to plastics and cause cracking. Not covered by any warranty.
- Our windshields are made from the highest quality material providing optimum transparency and clarity. Blurriness and/or extrusion marks may or may not appear when looking through windshield from a wide, side-angle. This is normal for all extruded clear plastic materials.
- The application of improper cleaners, abrasive and/or dirty cleaning towels can severely damage the product. Failure to follow cleaning recommendation (provided herewith) may void any warrantable components.

**DEALER**

**These instructions contain important information for future reference and must be given to the customer at time of purchase or upon completion of installation.**

**Parts List** (parts available with kit only and not available separately)

ITEM	PART NAME	DESCRIPTION	QTY	
A	Rear windshield	CNC windshield cut-out made of 1/8" thick GE polycarbonate or equivalent	1	
B	Vent grill (#T10)	CNC vent grill cut-out made of 3/16" tint polycarbonate	1	
C	Co-extruded bulb seal (1/4")	Includes: 168" Co-extruded bulb seal (1/4") / #77-95BS [end user to cut to exact length]	1	
INSTRUCTION BAG	D	Bracket & foam	Includes: 1 upper bracket and 1 adhesive foam strip 1/8" x 1" x 4" long	1
	E	Windshield Hardware	Includes: 4 metal plate hooks, 4 philips truss head screws M6 x 20, 2 philips truss head screws M6 x 24, 1 philips truss head screws M6 x 40, 9 plastic shoulder washers M6, 2 locknut M6 and 1 flanged locknut M6, 1 round spacer 1/2"	1
	F	Vent hardware	Includes: 2 carriage bolts M6 x 30, 2 thin plastic washers, 4 plastic washers M6, 2 rubber washers M6 and 2 female thread knobs M6	1

**1. Installation**

- a) Find a clean flat area where you can lay down the windshield (Item A). Partially remove the protective film on both sides and apply the co-extruded bulb seal (Item C) starting at bottom center of the windshield using manual pressure to ensure good adhesion. At the start/finish of the bulb seal, cut an extra 1/4" more than required. This will ensure a tight fit between the start and finish of the bulb seal.

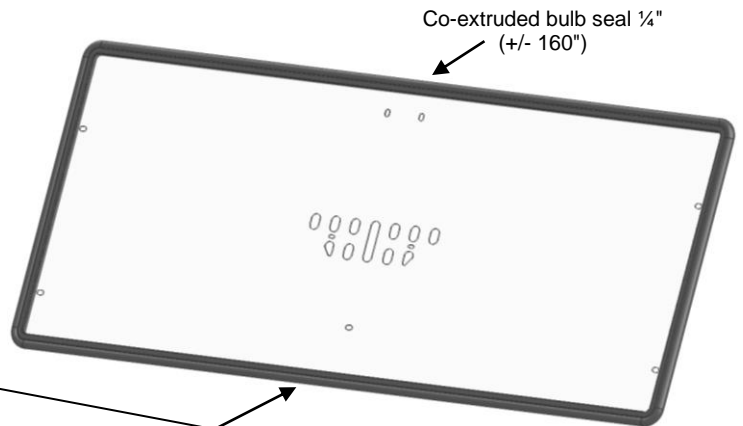
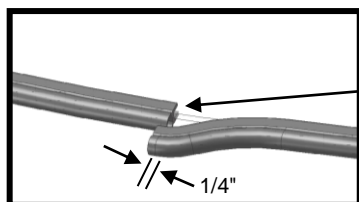

# IMPORTANT NOTICES

**Over-tightening any and/or all screws will cause cracks around mounting holes which is not covered by any warranty.**

- b) Find a clean flat area where you can safely lay down the windshield. Partially remove the protective film on both sides and install the vent grill (Item B) using supplied hardware (Item F) as shown.

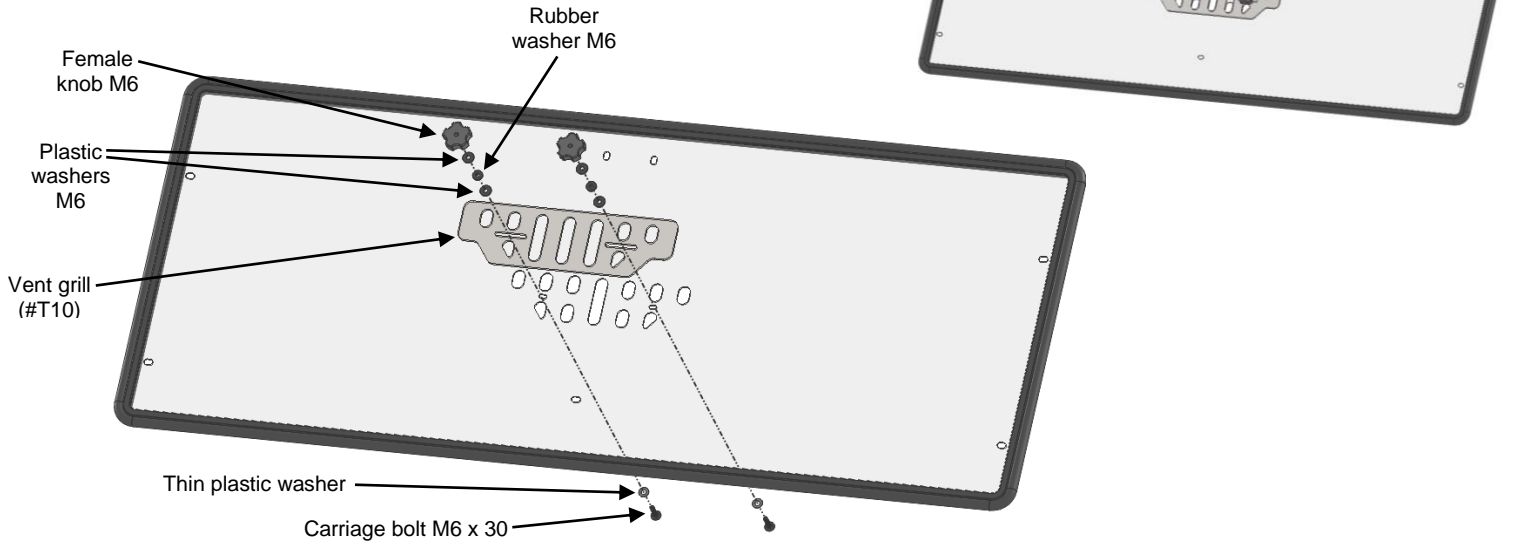

- c) Partially remove the protective film on the polycarbonate upper bracket (Item D) apply the self-adhesive foam cushion (Item D) using manual pressure to ensure good adhesion as shown below and cut any excess.

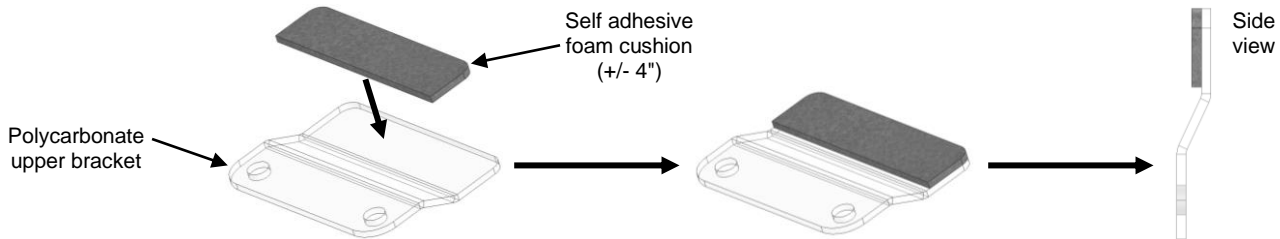

- d) Use the remaining of the co-extruded bulb seal (Item C) and apply 2 section of 4" to the headrest steel support as shown below.

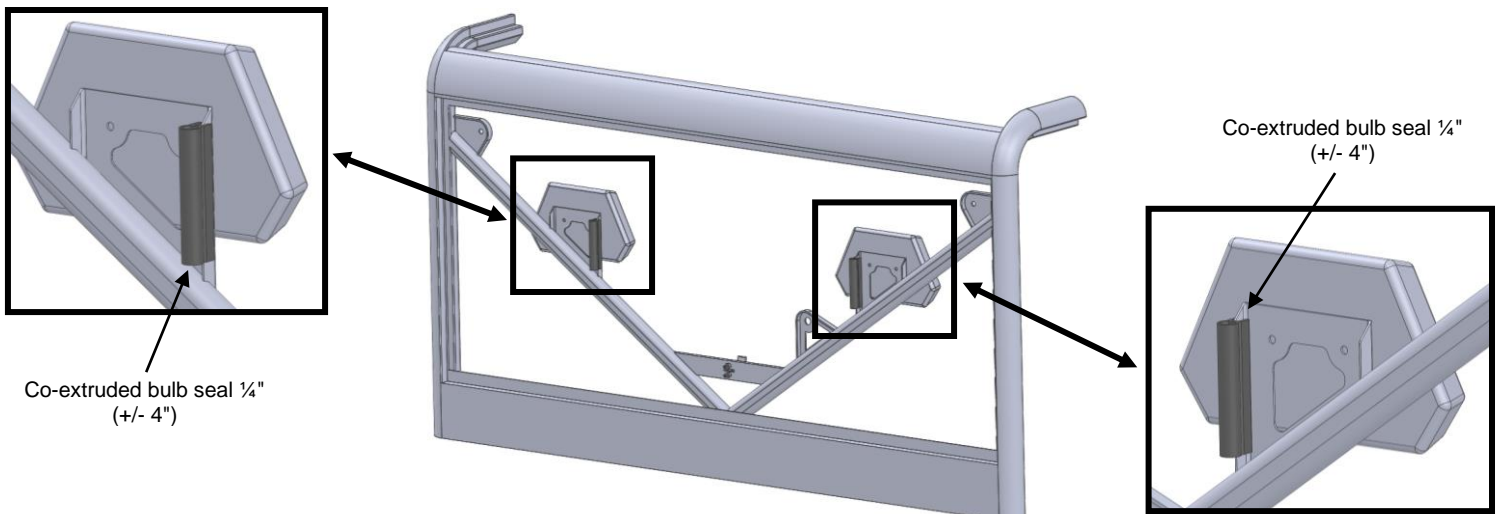

## IMPORTANT NOTICES

Torque specifications must be followed when tightening bolts.

Over-tightening any and/or all screws will cause cracks around mounting holes which is not covered by any warranty.

- e) As shown below, remove and discard the upper OEM screw (only the upper screw) that secure the OEM rubber strap holding the middle backrest section up. This empty hole will be used to secure the rear windshield in step f).

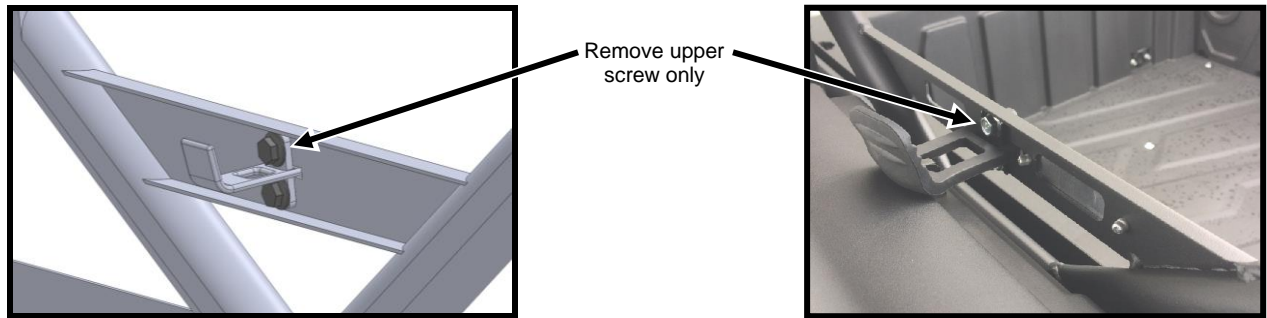

- f) Install the windshield to the vehicle using supplied hardware (Item E) as shown below. Adjust the position of the windshield and tighten. **Caution: over tightening any hardware could cause irreversible damage to the windshield.**

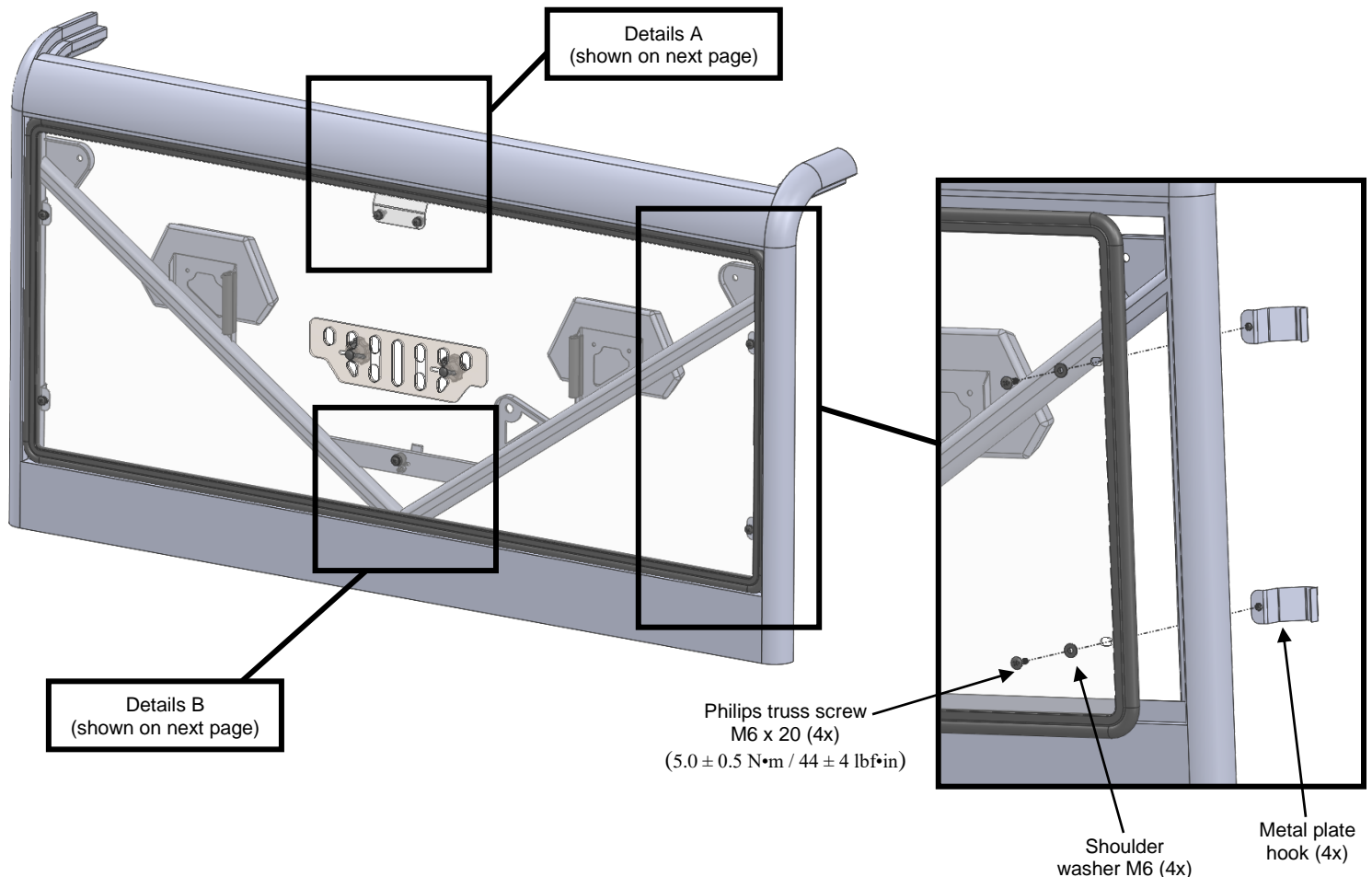

## IMPORTANT NOTICES

Torque specifications must be followed when tightening bolts.

Over-tightening any and/or all screws will cause cracks around mounting holes which is not covered by any warranty.

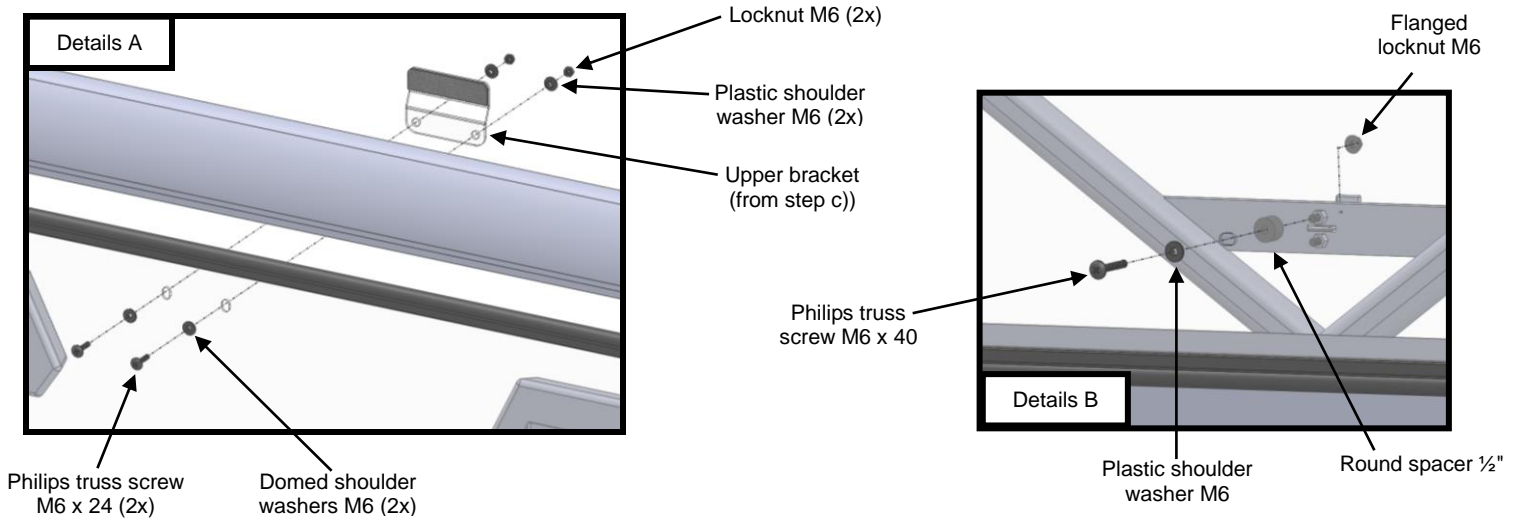

## IMPORTANT NOTICES

Trailerable **ONLY** with a **FULL** Front windshield **AND** Roof - or damage can occur!

### CAUTION

Please understand that open trailer towing can result in windshield/roof damage due to high wind pressure and road debris. Towing at Highway Speeds (75+ mph) for **EXTENDED** periods (over 100 miles) causes constant and extreme pressure at the mount areas, and is not recommended. Spike suggests removal of roofs/windshields if towed in these conditions-removal will also create less drag on the tow vehicle. Lower speeds (60 mph) or two-lane roads are no problem.

## 2. Maintenance and Care

Tighten all hardware after first use and periodically thereafter.

### CLEANING:

- Rinse with lukewarm water; wash gently with mild soap or detergent and lukewarm water, using a soft cloth or sponge. **DO NOT SCRUB** or use brushes or squeegees.
  - Rinse again. Dry with soft cloth or moist cellulose sponge to prevent water spotting.
- To remove wet paint, glazing compound or grease, rub lightly with a good grade of VM&P naphtha or isopropyl alcohol, then wash and rinse. **DO NOT USE GASOLINE.**

**NOTICE:** Abusive cleaning procedures by hand washing or automated washing equipment will eventually result in visual hazing, loss of light transmission and coating delamination.

#### Compatible Cleaning Agents

- Aqueous Solution of Soaps and Detergents

Joy | Freon T.F. | Palmolive liquid | Top Job | VM&P grade Naphtha | Windex (with ammonia D)

### MINIMIZING HAIRLINE SCRATCHES

For minimizing scratches and minor abrasions, mild automobile polish can be used.

Recommended products: Johnson Paste Wax, Novus Plastic Polish #1 and #2, Mirror Glaze plastic polish and Plexux1.

Testing polish on a separate Lexan sample is recommended. Be sure to follow product instructions carefully.