



655 Elm Ridge Ave, Canal Fulton OH, 44614  
Phone: 866-576-5115- SpikePowersports.com  
Email: [sales@spikepowersports.com](mailto:sales@spikepowersports.com)

**Contents:**

Qty	Description	Part Number
1	Upper Door Compression mold with Frame, left	n/a
1	Upper Door Compression mold with Frame, right	n/a
2	Latch Release Paddle Handle	P46-1325
2	Latch Cable	P49-1039
2	Upper Hinge Bracket A	P45-1521
2	Upper Hinge Bracket B	P45-1522
1	Upper Hinge Bracket C Left	P45-1523
1	Upper Hinge Bracket C Right	P45-1524
1	Edging Rubber Black D shaped @ 10''	P10-1042
14	M6 Fender Washer Black	P47-1231
6	M6x16mm Screw Black	P47-1234
6	Shroud Clip Steel Black	P45-1464
8	M6 Flanged Nylock Nut	P47-1388
1	Latch Lever Steel Black Left	P45-1510
1	Latch Lever Steel Black Right	P45-1511
2	Latch Cable Standoff Steel Black	P45-1512
2	Cotter Pin	P47-1138
2	M6 Nylock Nut	P47-1210
2	Washer Plastic White	P47-1305
2	M6x18mm Partial Thread Screw Black	P47-1312
4	M6x20mm Screw Steel	P47-1452
2	M6x45mm Screw Steel	P47-1236
2	M5x30mm Thread Forming Screw	P47-1446
4	M8x25mm Screw Steel Black	P47-1327
12	M8 Washer Steel Black	P47-1242
4	M8 Flanged Nylock Nut	P47-1353

4	M4x16mm Screw Steel Black	P47-1447	
4	M4 Nylock Nut Black	P47-1448	
1	Instruction Sheet		

**Tools Required:**

- Safety glasses
- 7 mm wrench
- 10 mm wrench
- 13 mm wrench
- 10 mm socket and ratchet
- T20 Torx driver
- T30 Torx driver
- T40 Torx driver
- Awl
- Heat Gun
- Hand drill
- ¼" Drill Bit
- 11/64" Drill Bit
- Dremel Tool
- Soldering iron (a hand drill with ¼" and 5/16" bits may be used instead, see notes below)

**Approximate Assembly Time:** 2 hours

**Safety Information:**

- You must wear eye protection and appropriate gloves when installing this kit.
- The engine must be OFF when performing any operation on the vehicle.
- Always be aware of parts that can move, such as wheels, transmission components, etc.
- Some components may be HOT. Always wait for the engine to cool down before performing work.
- Door is not intended to retain and/or protect occupants.
- Subtract the weight of the accessory from the weight limit of the vehicle.

**Always:**

- o Fasten your seat belt
- o Fasten lateral net.
- o Keep your entire body inside the cockpit.
- o Latch the door before riding.
- o Transport this vehicle facing forward.
- o Remove nets when using full doors only if required due to installation of the full doors.
- o Do not rest elbow on door while riding.
- o If nets are removed, reinstall nets if doors are removed.
- o Never operate UTV without either door or nets in place.
- o Inspect for safety problems, loose hardware, and loose buckles and straps before use.

**Use and Care Information:**

- To clean, sponge with mild soap and cold water, rinse with a hose and allow it to drip-dry.
- Do not machine wash or dry.
- Use mild detergent to remove stubborn stains.
- When not in use, the window roll-up strap can be snapped to itself or otherwise stowed.
- The zipper should be cleaned using a toothbrush with soap and water and rinsed as needed. Once the zipper is cleaned, the teeth should be lubricated using beeswax or zipper specific lubricant.

**Important:**

- This Spike Power Sports Door Set is exclusively designed for use with the Honda Talon vehicle.
- Before beginning, read the installation instructions carefully, completely and verify that all components are included in this kit.
- Installation is easiest if the vehicle is clean and free of debris.
- UTV vehicle preparation including cleaning and installing adhesive backed fasteners must be done indoors at room temperature. All adhesives must be given 24 hours to dry before operating.
- The instructions are written and the photos show installation to the left side of the vehicle. All steps must be performed on both sides of the vehicle.
- The illustrations/photos in this document show typical construction of the different assemblies and may not reproduce the full detail or exact shape of the parts; however, they represent parts that have the same or similar functions.
- Install all fasteners to the torque specified in the factory service manual.



**Installation Instructions:**

<p>1) Uninstall the roof and its fasteners as instructed in the User's Manual.</p> <p>NOTE: Retain the removed hardware for later re-install.</p>	
<p>2) Uninstall the windshield and its fasteners as instructed in the User's Manual.</p> <p>NOTE: Retain the removed hardware for later re-install.</p>	
<p>3) Uninstall the rear window and its fasteners as instructed in the User's Manual.</p> <p>NOTE: Retain the removed hardware for later re-install.</p>	

4) Shroud Installation

Align front shroud with the ROPS. Slide the lower corner of the plastic along the ROPS into the opening in the front fender.

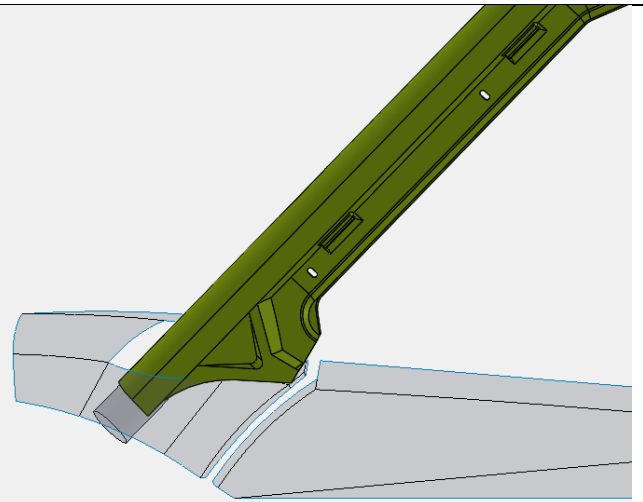

5) Hook each Shroud Clip (3) to the tabs on the shroud as shown. The 3<sup>rd</sup> tab will be used in a later step.

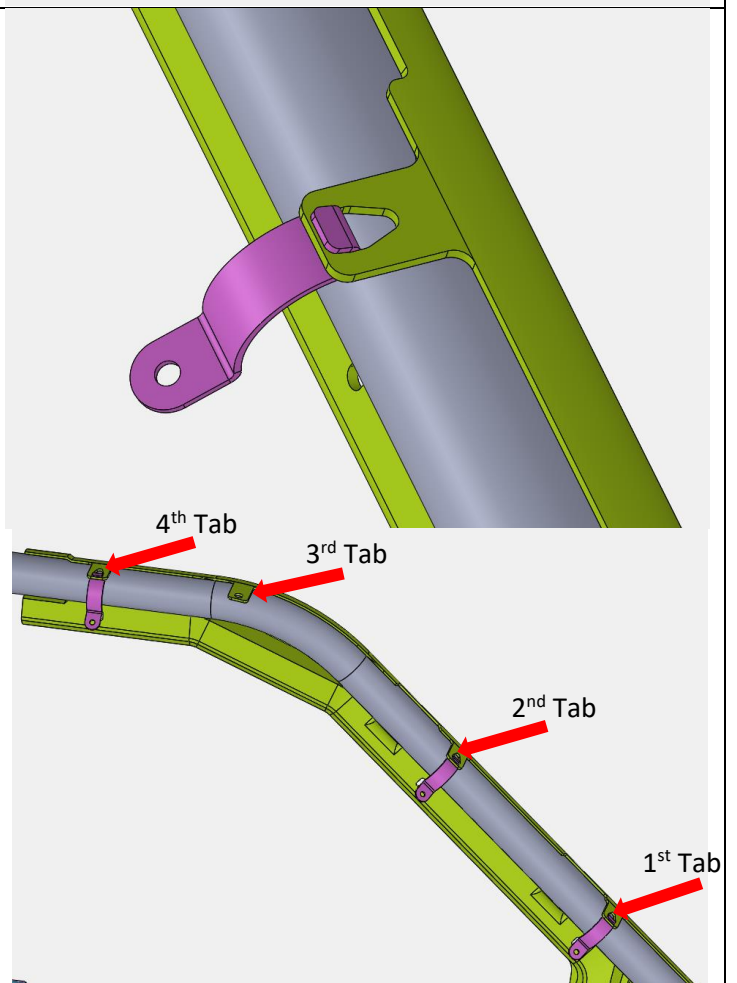

- 6) Fasten the plastic shroud to the clips using M6 x 16mm bolts (3), M6 Fender Washers (3), and M6 Flange Nuts (3) as shown.

Do not fully tighten the bolts at this time. The shroud should be secure, but still be able to move for adjustment later.

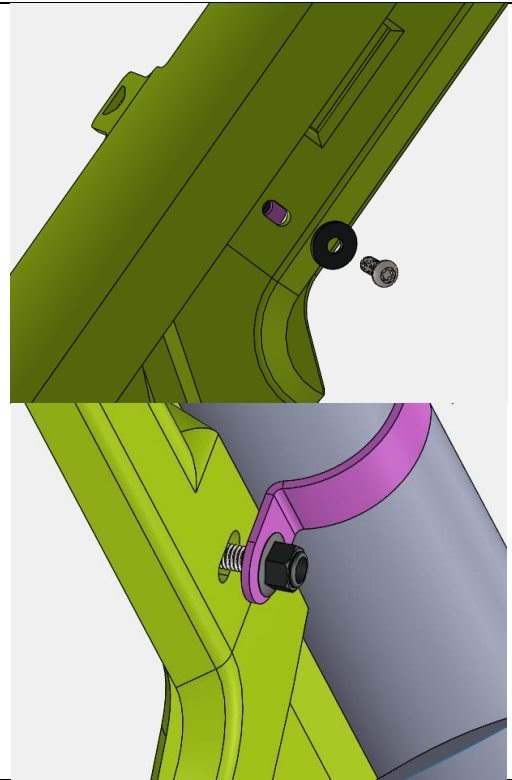

- 7) Hinge Bracket Installation  
Mount the Upper Hinge Bracket A and Upper Hinge Bracket B on the ROPS joint section.

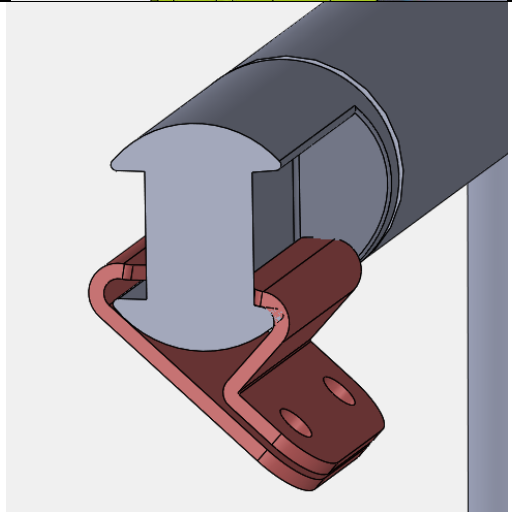

8) Position the Upper Hinge Bracket C Left, to line up with the holes making sure the small hole faces the front of the vehicle.

Fasten using M8x25mm Bolts (2), M8 Washers (2), and M8 Flange Nuts (2) as shown.

Do not fully tighten the screws at this time. The hinge brackets should be secure, but still be able to move up and down for adjustment later.

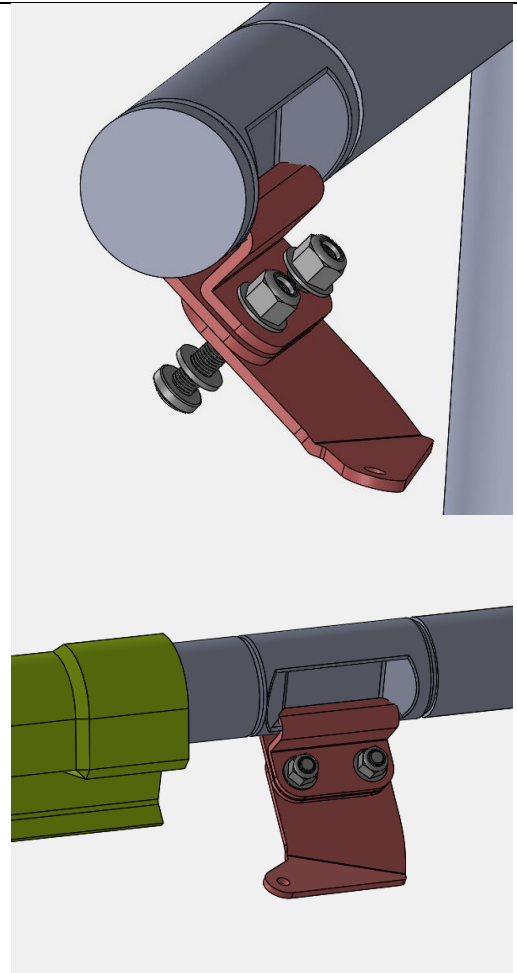

9) Lower Door Preparation

Uninstall the Outer Plastic panel on the Lower Door and its fasteners (7) as instructed in the User's Manual.

NOTE: Retain the removed hardware for later re-install.



10) Uninstall the 3 fasteners at top edge on the inside of the lower door.

NOTE: Retain the removed hardware for later re-install.





11) Uninstall the two push pin rivets.

NOTE: Retain the removed hardware for later re-install.



12) Door Installation

Note: Door in accompanying images is shown without the compression molded exterior for clarity.

Note: Unzip the clear window for easy access during installation.

Slide the top front section of the rear half of the compression molded door under the top lip of the plastic shroud.

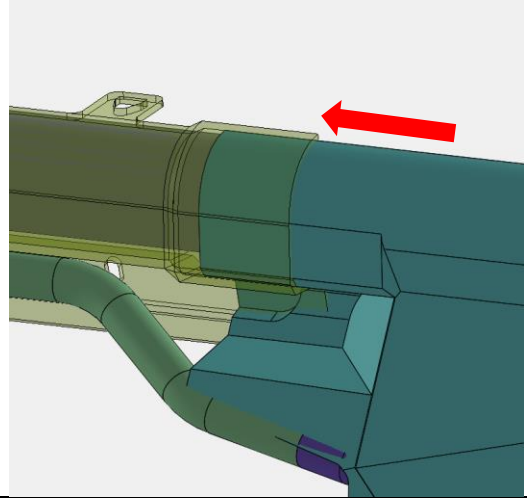



13) Mount the compression molded door with metal tube to the lower plastic door frame. Fasten the rotating barrel to the Upper Hinge Bracket C Left.

Use M6x18mm Partial Threaded Screw, White Teflon Washer, and M6 Nylock Nut as shown.

Note: The Teflon washer must be used between the bracket and the hinge.

Do not fully tighten the screws at this time. The hinges should be secure, but still be able to move up and down for adjustment later.

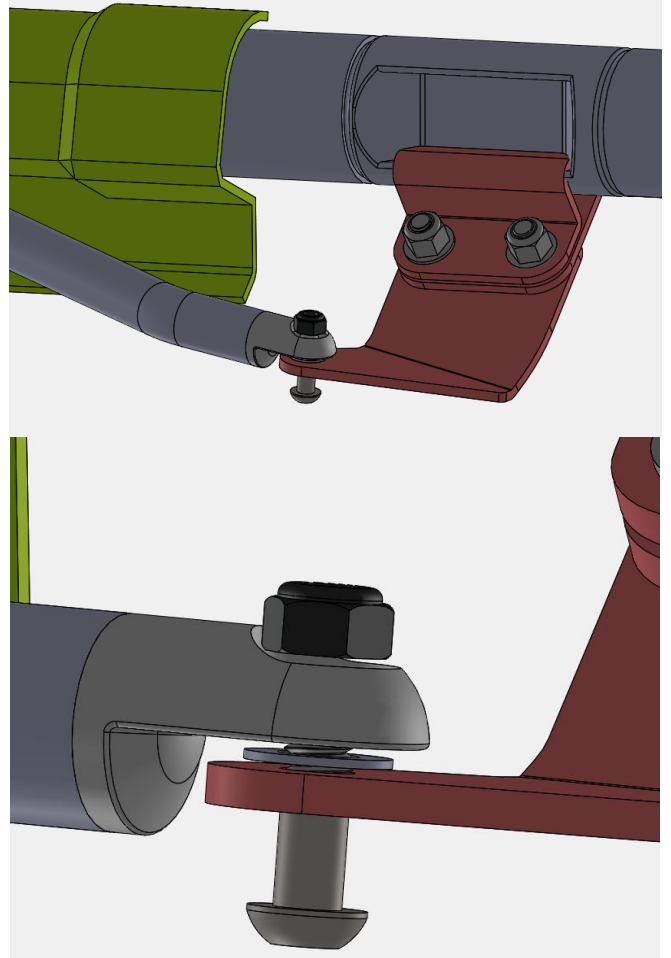

14) With the lower door near the closed position, fasten the first bracket to the threaded hole using a M6x20mm Screw and M6 Fender Washer.

Do not fully tighten the screws at this time. The hinge brackets should be secure, but still be able to move for adjustment later.

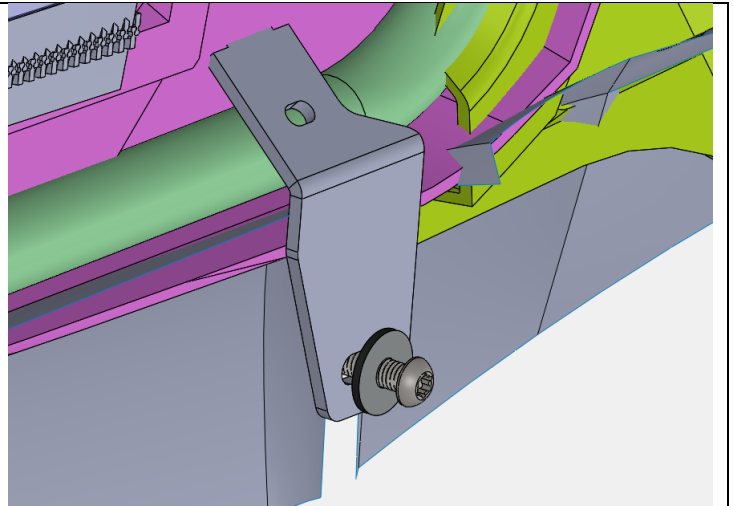

15) Fasten the webbing with metal grommet to the threaded hole at the rear section of the lower door using a M6x20mm Screw and M6 Fender Washer.

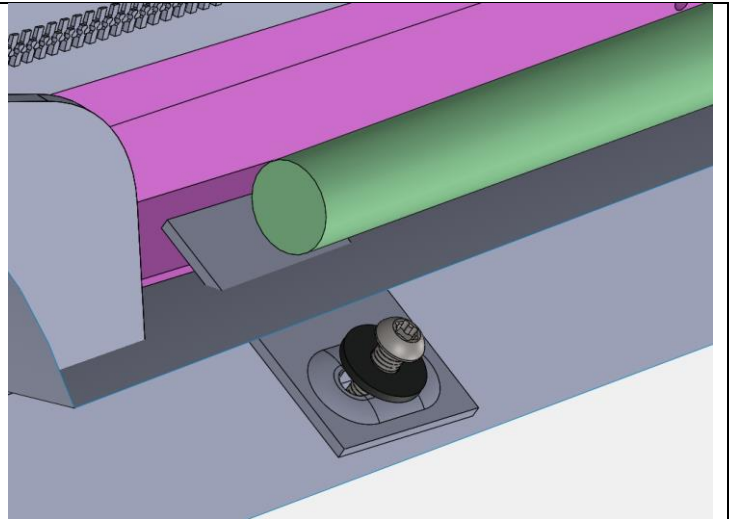

16) The mid bracket overlays a slot shaped indent on the lower plastic door. Adjust to align the lower hole of the bracket close to the center of the indent. Mark the position with an awl and drill a ¼" through hole in the plastic door.

Fasten using a M6x45mm Screw, M6 Fender Washer, and M6 Flanged Nylock Nut as shown.

Note: The slotted hole will be fastened in a later step.

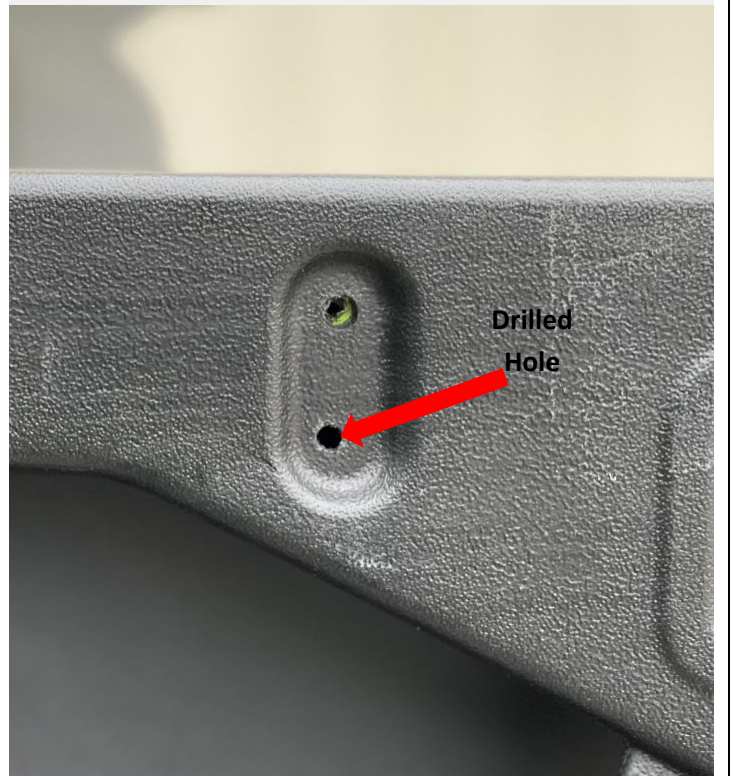
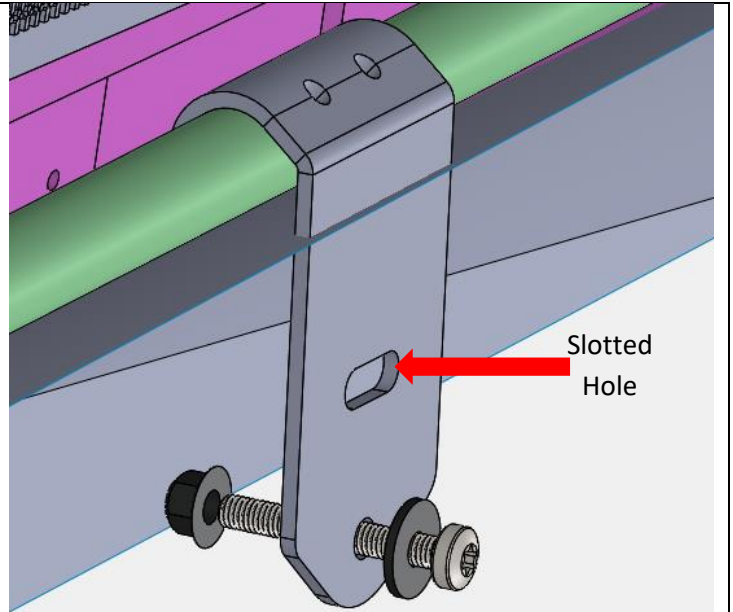

17) Fasten the rear half of the compression mold to the ROPS tube using the hook and loop fasteners sewn to the rear section.  
Wrap and pull tight to attach the hook and loop fastener around the ROPS at all 5 places. Retighten if needed to remove any wrinkles or realign.

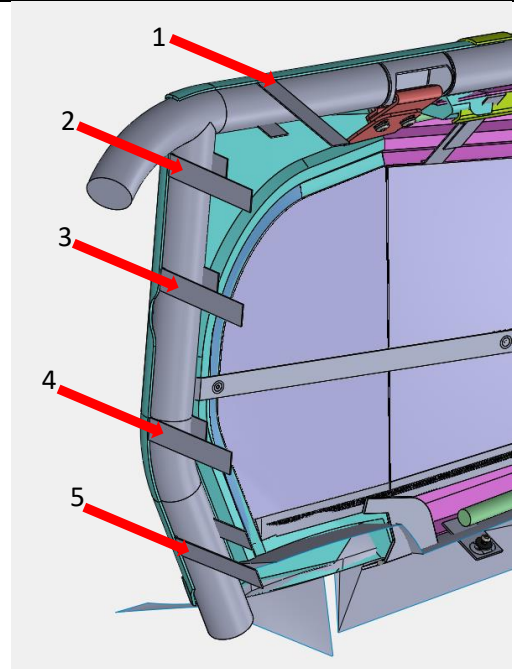

18) Align and mark the push pin dart holes on the compression mold. Use a soldering iron to burn holes at the two marked locations through the skin.

NOTE – Make sure the upper door is free of wrinkles and aligned well to the vehicle before making the holes.

IMPORTANT – This step requires extra care in order to not damage the compression molded door skin.

Reuse the push pin rivets removed in an earlier step to install the skin to the vehicle.

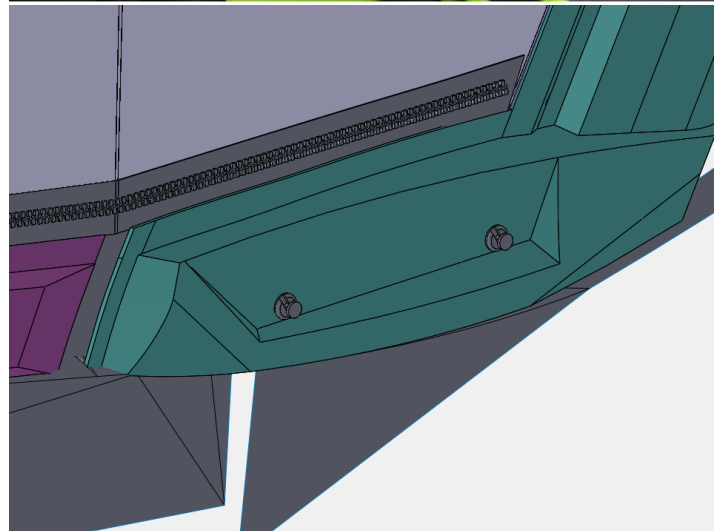

19) Swing the door open to make sure the compression mold doesn't pucker at the hinge axis and swivels smoothly with the lower door.

Tighten down all fasteners.





20) Mirror Installation (Optional Accessory)

Mark the center of the hole on the compression molded door from the inside. Use a soldering iron to burn a hole through the compression molded door skin.

IMPORTANT – This step requires extra care in order to not damage the compression molded door skin.

NOTE – A razor knife may be used instead of a soldering iron.

Install per the instructions included with the mirror.

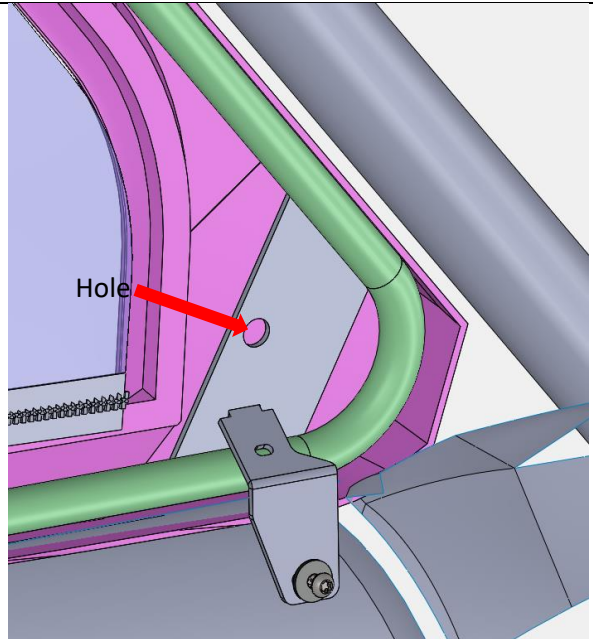



21) Outside Handle Installation

Uninstall the latch on the lower door. Retain hardware for later re-install.

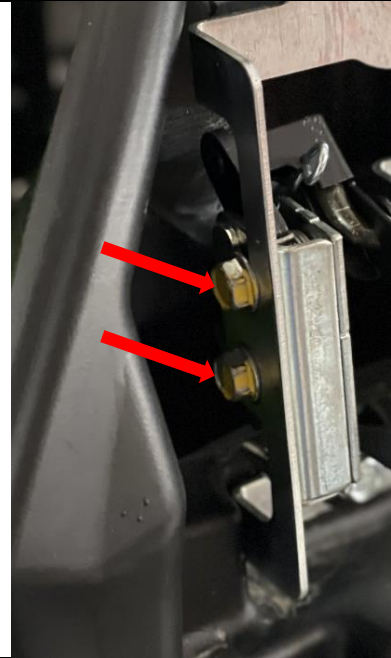

22) Slide four M8 Washers on to the actuating rod followed by sliding the Left Latch Lever on through the side hole.

Once in position fasten using a cotter pin as shown.

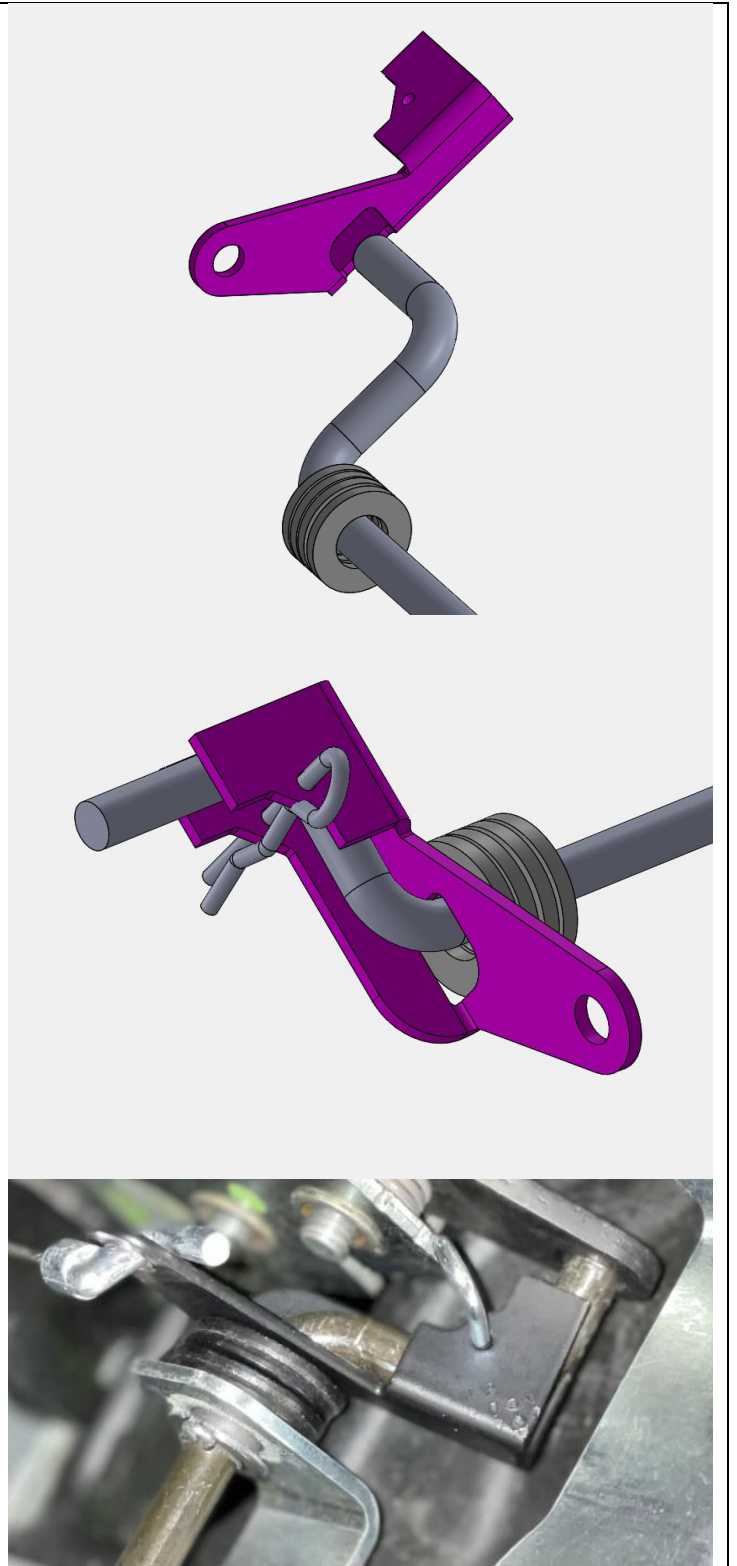

23) Reinstall the latch to the door.

24) Uninstall the screw shown in the image.

Mount the Latch Cable Standoff and reinstall the screw.

Make sure the Latch Cable Standoff is oriented correctly while installing.



25) Mount the Z end of the cable through the hole on the Latch Lever and snap the ring on the end cap casing into the Latch Cable Standoff.

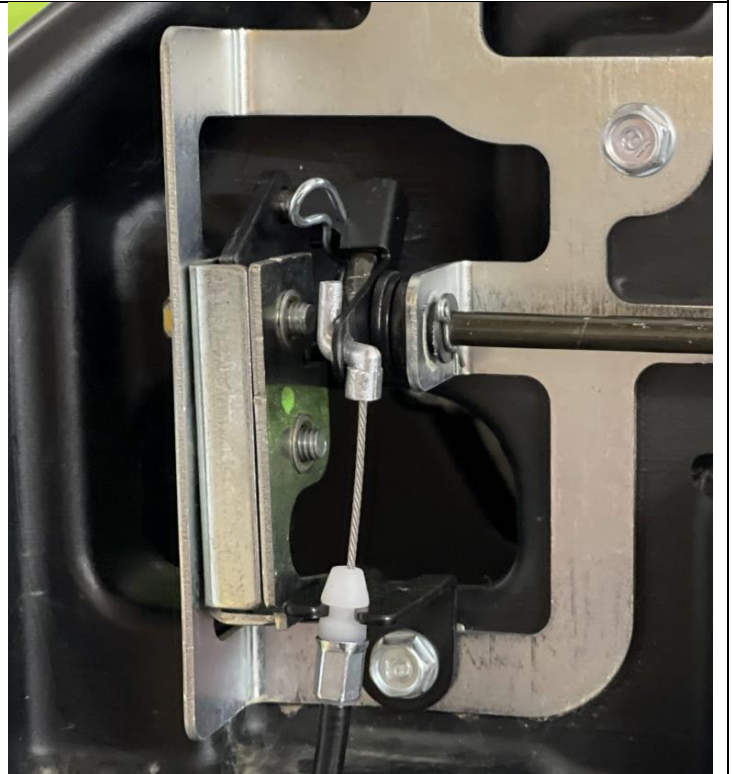

26) Print the template provided at the end of the document keeping the Scale 1:1. Cut the drawn portion using scissors.

Place the Template on the inside of the plastic panel and line it up along the top and front bend lines edges on the plastic panel. Mark the corners of the rectangular hole and two circular holes.

Use a Dremel tool to cut the rectangular hole and deburr the edges of the cutout with a Handle Deburr knife or similar tool.

Use a 11/64" bit to drill out the two circular holes.



27) Insert the Handle from the front of the panel making sure it is oriented correctly with the handle flap facing the front of the vehicle.  
Install using M4x16mm Screw (2) and M4 Nylock Nut (2).



28) Install the Barrel End Fitting to the handle by sliding the cylindrical portion into the hole and snapping the ring on the end cap casing into circular cutout.



29) Test the latching system to make sure the setup works correctly. Adjustments can be made to by changing the snapping position on the 3 Ring Fitting End Cap Casing.

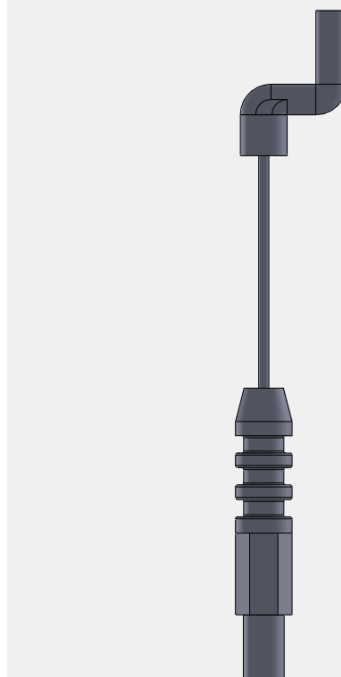

30) Reinstall the outer plastic panel to the lower door.



31) The slotted hole on the mid bracket is now fastened to the Outer Plastic Panel using a M5x30mm Thread Forming Screw and M6 Fender Washer.



32) The 3<sup>rd</sup> Tab on the Front Shroud (Step 5) will use the screw from the roof to be fastened to the vehicle.

Make sure the slot lines up with the threaded hole in the ROPS Weldment.

33) Cut and attach the D Rubber Seal at the top center overlap of the front and rear half of the compression mold.



34) Adjust the hook and loop Velcro for best fit at the top center overlap.



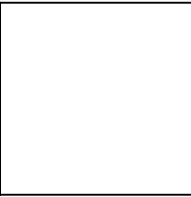
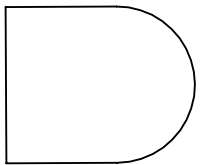
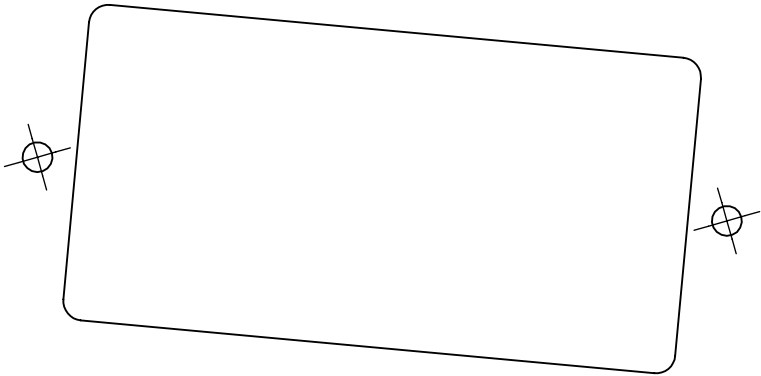

1"x1" Square  
To check scale