



**INSTALLATION INSTRUCTIONS  
CANAM MAVERICK X3  
REAR WINDSHIELD  
PART # 77-2300-R**

**IMPORTANT NOTICES**

**READ AND UNDERSTAND THESE INSTRUCTIONS COMPLETELY BEFORE INSTALLATION TO AVOID INJURY TO YOURSELF, DAMAGE TO THE VEHICLE OR ACCESSORY.**

- For proper installation, **TWO** people are required.
- Torque specifications must be followed when tightening bolts. Over-tightening any and/or all screws will cause cracks around mounting holes which is not covered by any warranty.
  - As specified on carton label, once protective film on shields is removed, product cannot be returned.
- As specified on carton label, damage caused by packaging staples is not covered by warranty. All staples must be removed prior to removing product from carton.
- Failure to follow these installation instructions completely may void any warrantable components and result in product damage or personal injury.
- Do not use Loctite or any other similar fastener adhesive. These types of products react to plastics and cause cracking. Not covered by any warranty.
  - Our windshields are made from the highest quality material providing optimum transparency and clarity. Blurriness and/or extrusion marks may or may not appear when looking through windshield from a wide, side-angle. This is normal for all extruded clear plastic materials.
- The application of improper cleaners, abrasive and/or dirty cleaning towels can severely damage the product. Failure to follow cleaning recommendation (provided herewith) may void any warrantable components.

**DEALER**

**These instructions contain important information for future reference and must be given to the customer at time of purchase or upon completion of installation.**

**Parts List** (parts available with kit only and not available separately)

ITEM	PART NAME	DESCRIPTION	QTY
A	Windshield	CNC windshield cut-out made of 1/8" thick GE polycarbonate or equivalent	1
INSTRUCTION BAG	B	Edge guard strip Includes: 10" edge guard strip for 1/8" wall thickness <b>[end user to cut to exact length]</b>	1
	C	Hardware Includes: 2 philips truss screws M6 x 20, 2 plastic shoulder washers M6, 2 plastic washers M6, 2 locknut M6 and 2 push type plastic retainers	1

**1. Installation**

- a) Find a clean flat area where you can safely lay down the windshield (Item A). Partially remove the protective film on both sides and apply the edge guard strip (Item B) to the lower edge as shown below using manual pressure to ensure good adhesion and cut any excess.

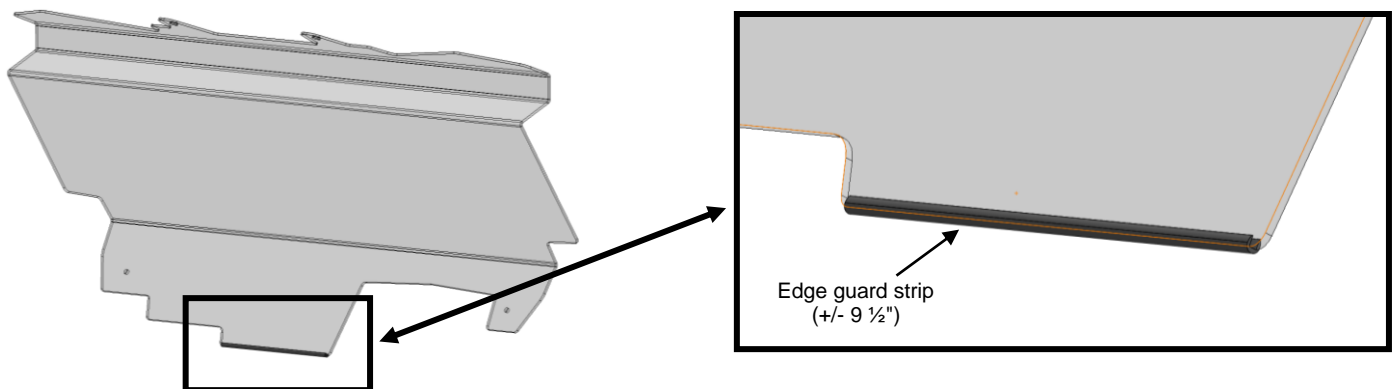

## IMPORTANT NOTICES

**Over-tightening any and/or all screws will cause cracks around mounting holes which is not covered by any warranty.**

- b) Slide down the windshield between the rear roll cage tubes and secure to the upper crossbar using supplied hardware (Item C) as shown below.

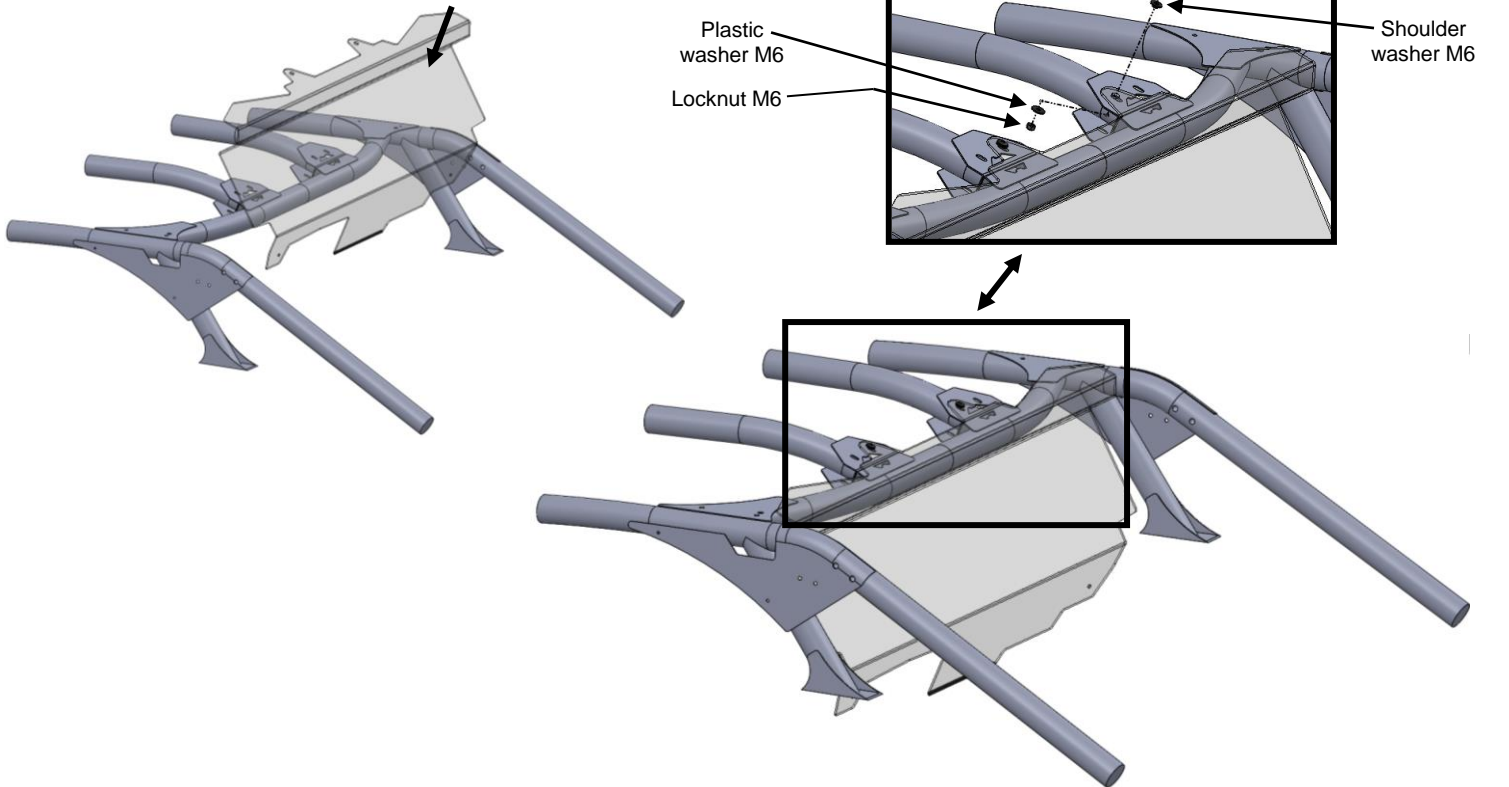

**Note:** Move both driver and passenger seats forward to facilitate next step.

- c) Ensure that the rear windshield is in proper position. From inside the cab, edge guard trim should fit snug in console groove, almost like a compression fit. Hold the windshield in place and ensure fit is 100% prior to drilling any holes in your vehicle. Drill a ¼ inch diameter hole through the rear upper bulkhead panels using the rear windshield lower mounting holes as a guide. Attach with supplied push type plastic retainers.

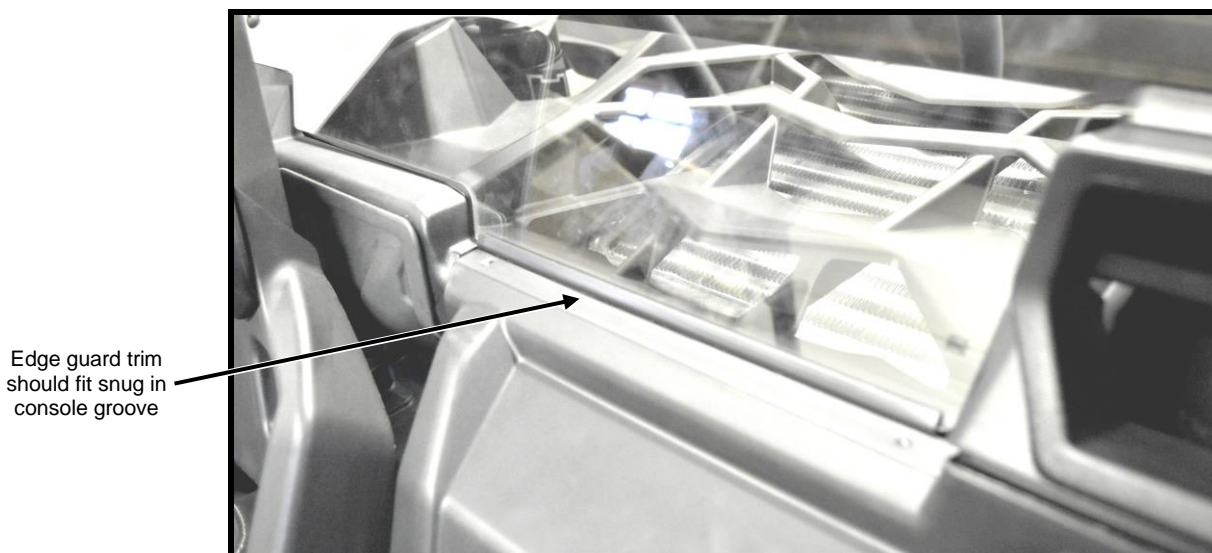

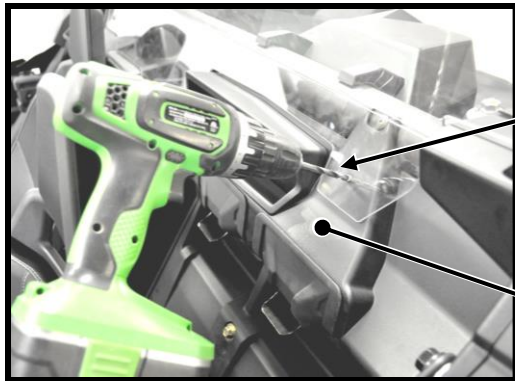
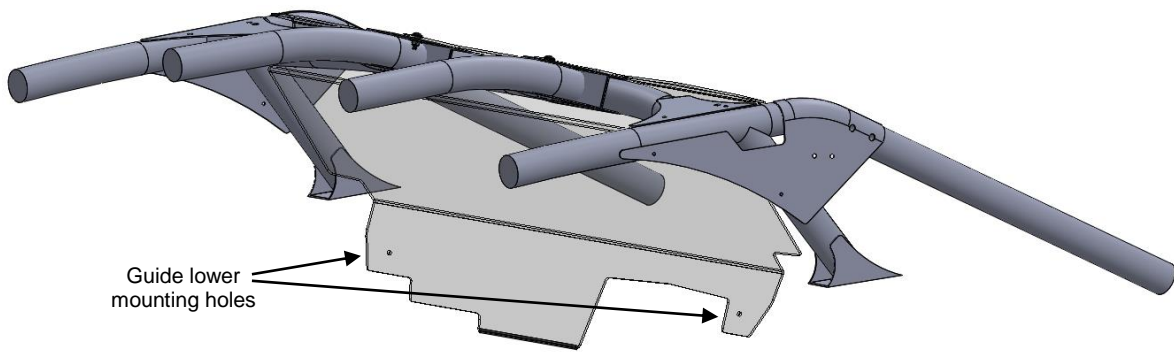

Drill bit 1/4" dia.

Bulkhead panel

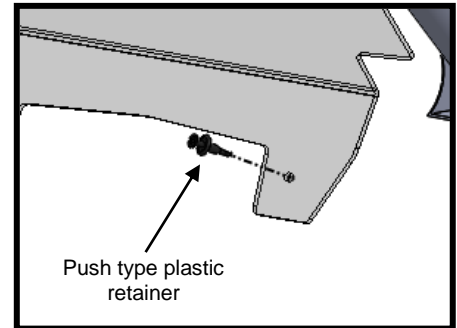

Push type plastic retainer

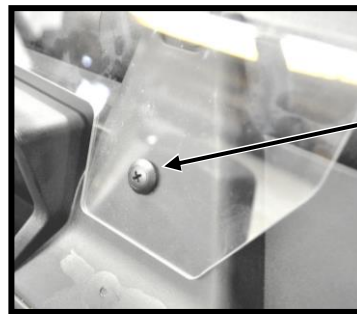

Push type plastic retainer locking position, screwdriver is not required, simply push

## 2. Maintenance and Care

Tighten all hardware after first use and periodically thereafter.

### **CLEANING:**

- Rinse with lukewarm water; wash gently with mild soap or detergent and lukewarm water, using a soft cloth or sponge. **DO NOT SCRUB** or use brushes or squeegees.
  - Rinse again. Dry with soft cloth or moist cellulose sponge to prevent water spotting.
- To remove wet paint, glazing compound or grease, rub lightly with a good grade of VM&P naphtha or isopropyl alcohol, then wash and rinse. **DO NOT USE GASOLINE.**

**NOTICE:** Abusive cleaning procedures by hand washing or automated washing equipment will eventually result in visual hazing, loss of light transmission and coating delamination.

#### **Compatible Cleaning Agents**

- Aqueous Solution of Soaps and Detergents

Joy | Freon T.F. | Palmolive liquid | Top Job | VM&P grade Naphtha | Windex (with ammonia D)

### **MINIMIZING HAIRLINE SCRATCHES**

For minimizing scratches and minor abrasions, mild automobile polish can be used.

Recommended products: Johnson Paste Wax, Novus Plastic Polish #1 and #2, Mirror Glaze plastic polish and Plexux1.

Testing polish on a separate Lexan sample is recommended. Be sure to follow product instructions carefully.