



INSTALLATION INSTRUCTIONS
KAWASAKI MULE MX
REAR VENTED WINDSHIELD
PART # 77-8850-R-T

IMPORTANT NOTICES

READ AND UNDERSTAND THESE INSTRUCTIONS COMPLETELY BEFORE INSTALLATION TO AVOID INJURY TO YOURSELF, DAMAGE TO THE VEHICLE OR ACCESSORY.

- For proper installation, TWO people are required.
- Torque specifications must be followed when tightening bolts. Over-tightening any and/or all screws will cause cracks around mounting holes which is not covered by any warranty.
 - As specified on carton label, once protective film on shields is removed, product cannot be returned.
- As specified on carton label, damage caused by packaging staples is not covered by warranty. All staples must be removed prior to removing product from carton.
 - ANY cutting, trimming, drilling or altering of this product as delivered is not covered under warranty.
- Failure to follow these installation instructions completely may void any warrantable components and result in product damage or personal injury.
- Do not use Loctite/Super Glue or any other similar fastener adhesive. These types of products react to plastics and cause cracking. Not covered by any warranty.
 - Our windshields are made from the highest quality material providing optimum transparency and clarity. Blurriness and/or extrusion marks may or may not appear when looking through windshield from a wide, side-angle. This is normal for all extruded clear plastic materials.
- The application of improper cleaners, abrasive and/or dirty cleaning towels can severely damage the product. Failure to follow cleaning recommendation (provided herewith) may void any warrantable components.

DEALER

These instructions contain important information for future reference and must be given to the customer at time of purchase or upon completion of installation.

Parts List (parts available with kit only and not available separately)

| ITEM | PART NAME | DESCRIPTION | QTY | |
|-----------------|------------------|---|--|---|
| A | Windshield | CNC windshield cut-out made of 1/8" thick GE tinted polycarbonate or equivalent | 1 | |
| B | Vent grill (#T5) | CNC vent grill cut-out made of 3/16" tint polycarbonate | 1 | |
| INSTRUCTION BAG | C | Co-extruded bulb seal (1/4") | Includes: 18" Co-extruded bulb seal (1/4") / #77-95BS [end user to cut to exact length] | 1 |
| | D | Foam cushion | Included: 30" of 1" x 1/8" self-adhesive foam cushion [end user to cut to exact length] | 1 |
| | E | Flop clamp set | Includes: 4 flop clamps and 8 injected rubber pad spacers (1 3/4") | 1 |
| | F | Hardware bag | Includes: 4 philips truss head screws M6 x 16, 4 philips truss head screws M6 x 20, 2 philips truss head screws M6 x 40, 10 plastic shoulder washers M6, 4 plastic washers M6, 4 washers M6 x 25, 6 locknuts M6 and 2 round spacers 1" | 1 |
| | G | Vent hardware | Includes: 2 carriage bolts M6 x 30, 2 thin plastic washers, 4 plastic washers M6, 2 rubber washers M6 and 2 female thread knobs M6 | 1 |

1. Installation

- a) Find a clean flat area where you can safely lay down the windshield (Item A). Partially remove the protective film on both sides and apply the self-adhesive foam cushion (Item D) to the upper lip using manual pressure to ensure good adhesion to the windshield and cut any excess.

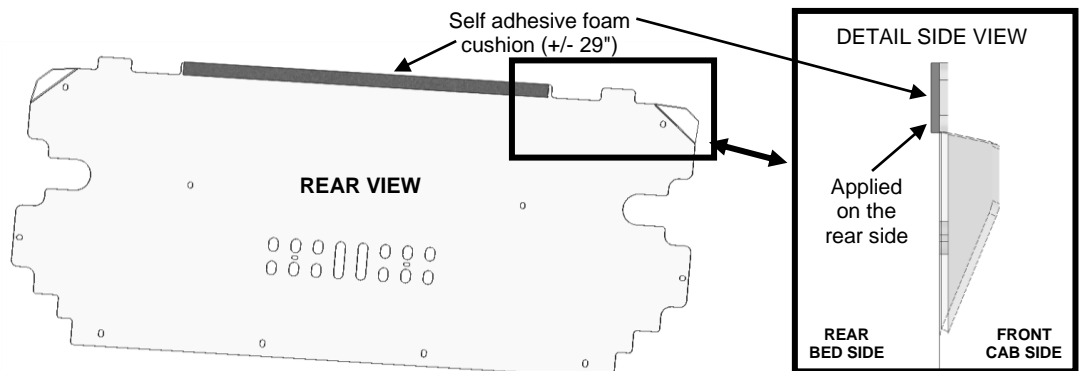

IMPORTANT NOTICES

Over-tightening any and/or all screws will cause cracks around mounting holes which is not covered by any warranty.

- b) Find a clean flat area where you can safely lay down the windshield (Item A). Precut two sections of the co-extruded bulb seal (Item C) to 8 ½". Partially remove the protective film on both sides and apply the precut co-extruded bulb seal sections to both right and left "U" shape windshield contour as shown below using manual pressure to ensure good adhesion.

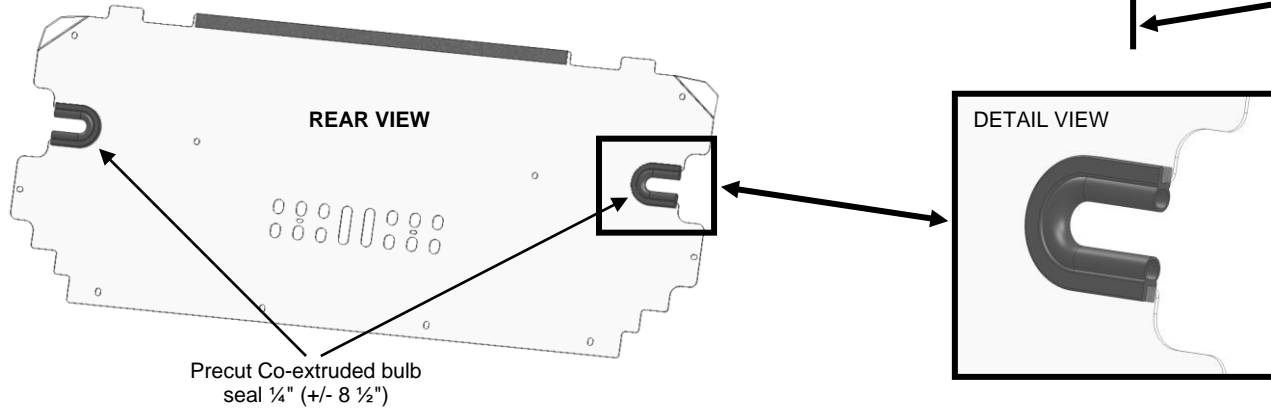
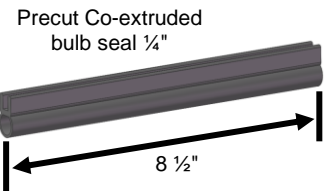

- c) Insert the injected rubber pad spacers (Item E) to all clamps as shown below.

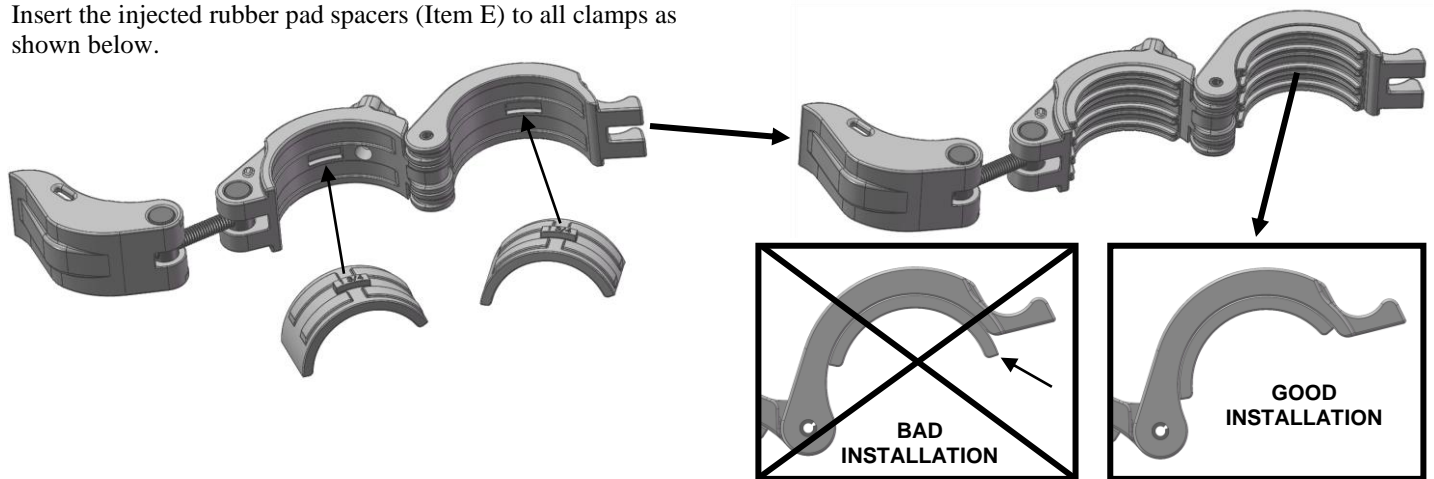

- d) Attach the clamps to the roll-cage as shown below and pre-adjust tightening tension of all clamps. **NOTE: Keep all clamp handles open as shown in step 3 below; this will allow you to move the clamps up or down when installing the windshield for the first time.**

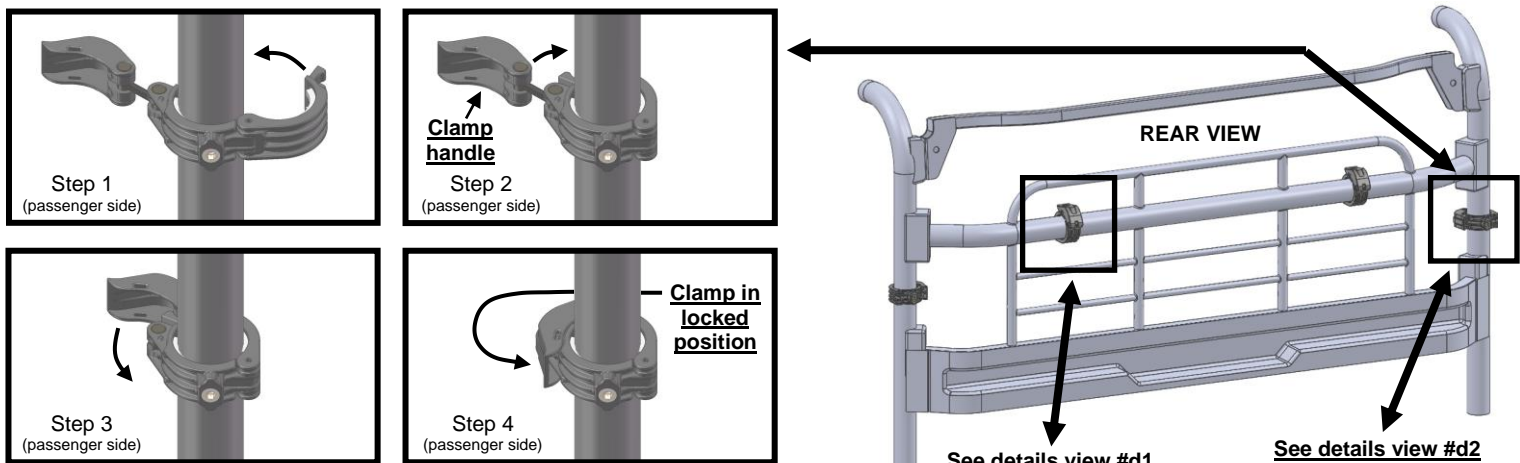

*** See clamps tension adjustment details on next page ***

IMPORTANT NOTICES

Torque specifications must be followed when tightening bolts.

Over-tightening any and/or all screws will cause cracks around mounting holes which is not covered by any warranty.

To apply more or less tension to the roll cage, simply rotate the clamp handle from the tension screw as shown below. Over tightening clamps to roll-cage could cause parts failures.

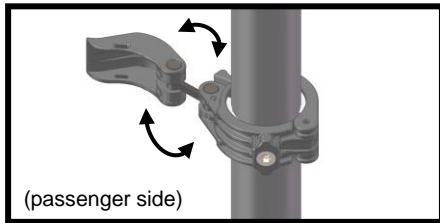

Details view #d1

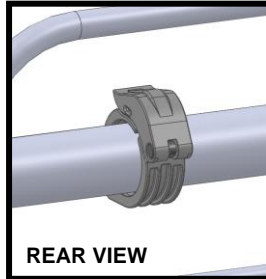

Details view #d2

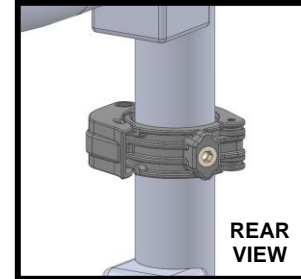

WARNING

The windshield is wider than the space between the roll cage pipes. In order to pass the windshield through the roll cage pipes; it will need to be gently curved and/or squeezed into position.

FOR EASIER INSTALLATION, TEMPORARILY REMOVE THE SEAT BELTS FROM THE UPPER ANCHORS. THIS WILL ALLOW MORE SPACE AND MORE FLEXIBILITY FOR THE REAR WINDSHIELD INSTALLATION.

- e) We strongly recommend adding extra protection (cardboard, towels ...) between the windshield and the vehicle at this step. This will protect both the windshield and vehicle against scratches during installation (**Do not remove protective film at this stage**). With two people, carefully slide the rear windshield (Item A) in place from inside the cab as shown below. When the windshield is properly positioned, remove protective film and attach the windshield to the clamps using supplied screws and washers (Item F) without applying final torque. Ensure that the windshield and all clamps are properly positioned. Secure all clamps in locking position [Ref: Step 4 - section e] and tighten all screws as shown below. **Over-tightening clamps to roll bar could cause parts failures.**

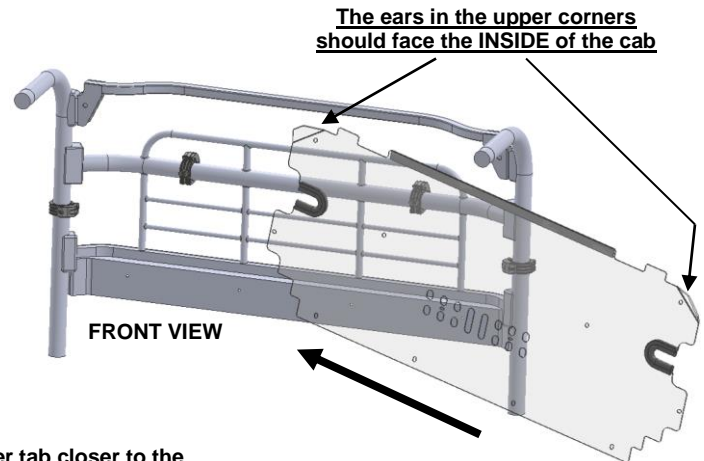

The center section with foam cushion fits on the inside of the transverse bar

The smaller tab closer to the edge fits on the outside of the transverse bar (both sides)

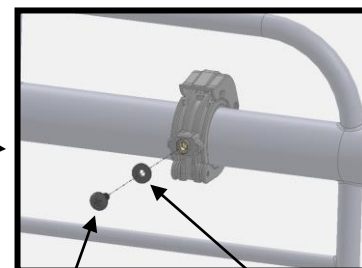
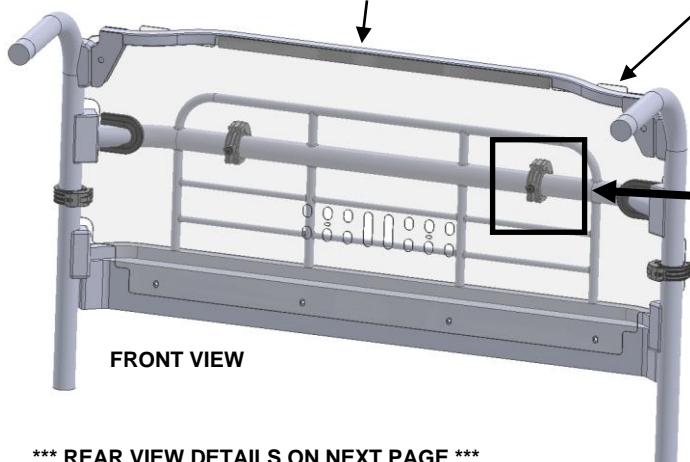

Philips truss screw M6 x 16
(5.0 ± 0.5 N•m / 44 ± 4 lbf•in)

Shoulder washer M6

*** REAR VIEW DETAILS ON NEXT PAGE ***

IMPORTANT NOTICES

Torque specifications must be followed when tightening bolts.

Over-tightening any and/or all screws will cause cracks around mounting holes which is not covered by any warranty.

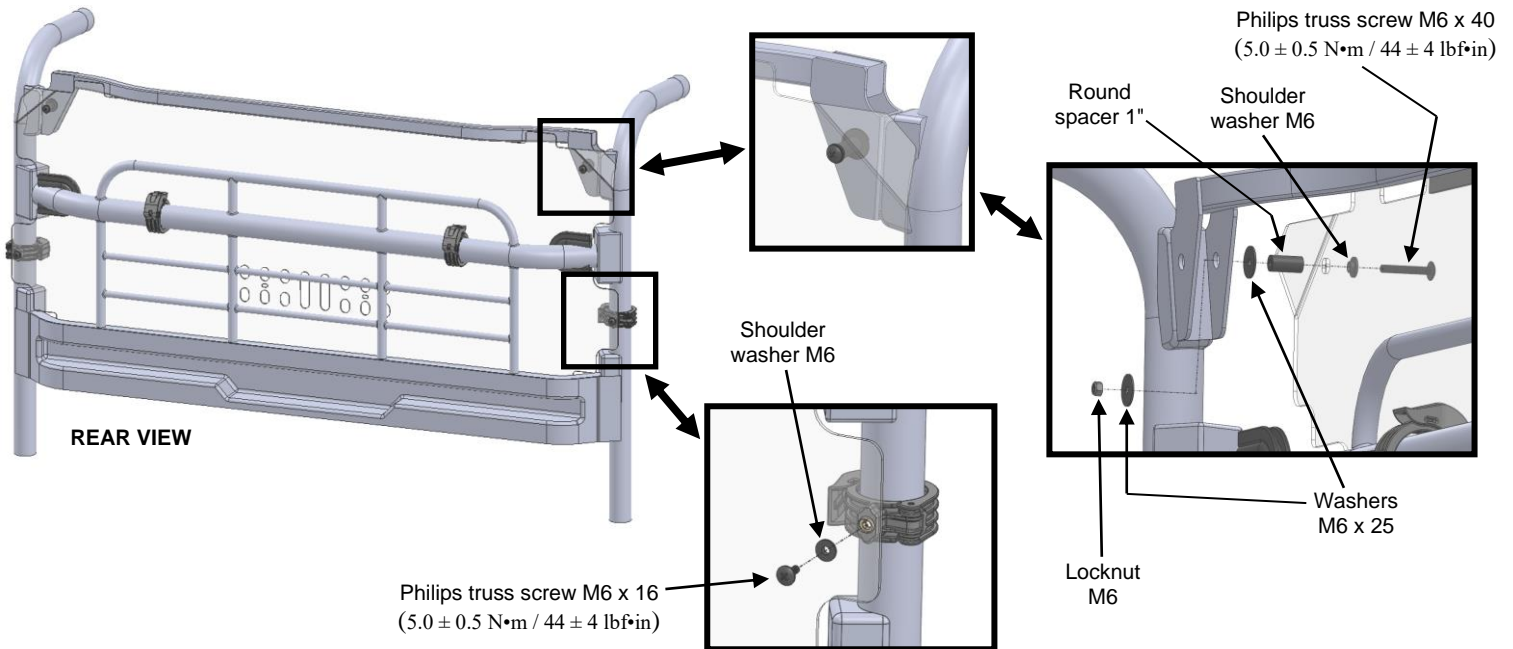

- f) Using the lower mounting holes of the rear windshield as a guide, drill $\frac{1}{4}$ " diameter mounting holes to the back-seat panel. Secure the rear windshield in place using supplied hardware (Item F) as shown. Tighten all screws & nuts.

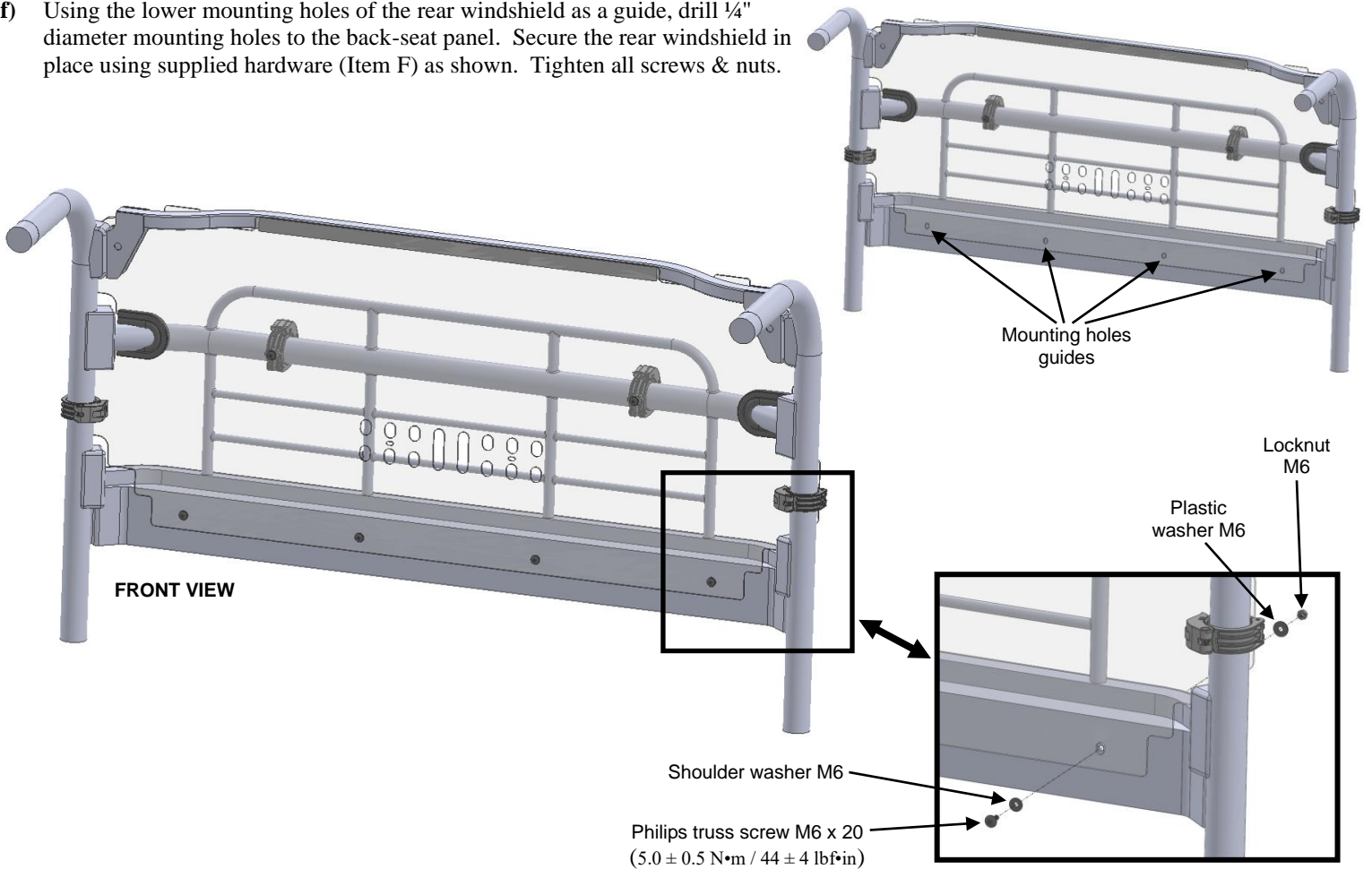

IMPORTANT NOTICES

Over-tightening any and/or all screws will cause cracks around mounting holes which is not covered by any warranty.

- g) Install the vent grill (Item B) using supplied hardware (Item G) as shown.

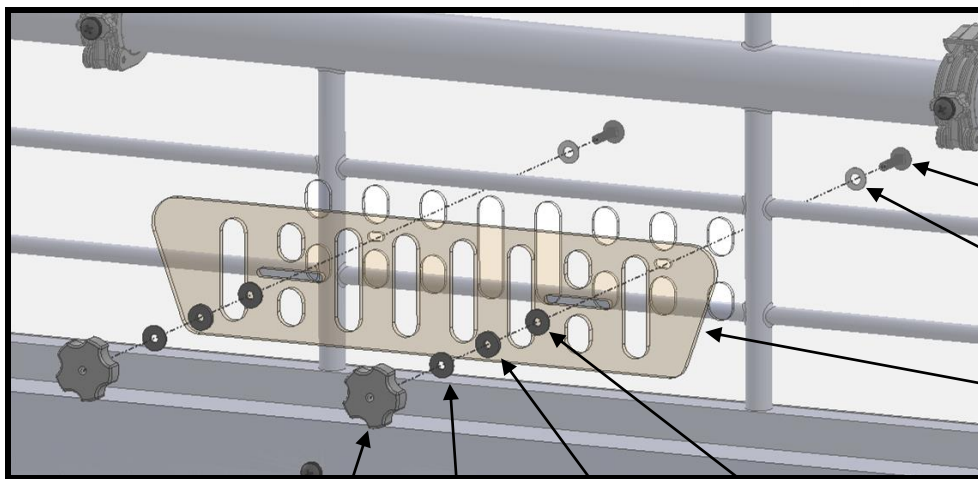
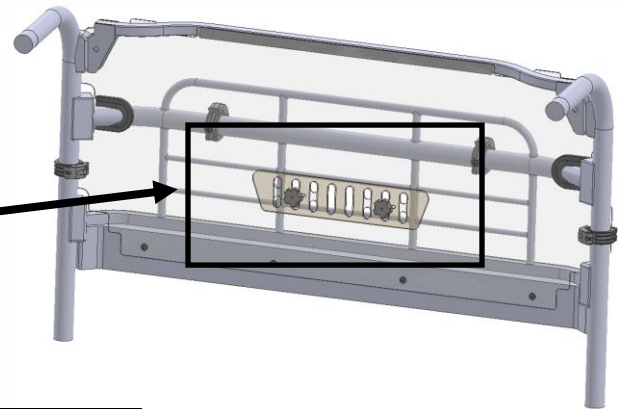
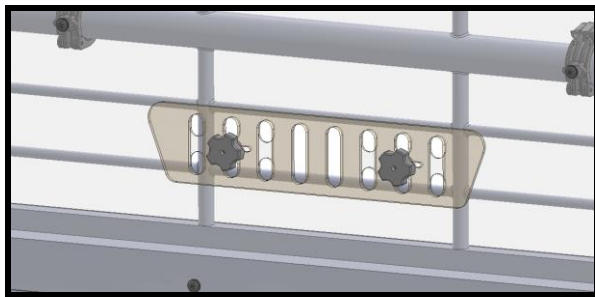

Female knob M6

Plastic washer M6

Rubber washer M6

Plastic washer M6

Carriage bolt
M6 x 30

Thin plastic
washer

Vent grill
(#T5)

IMPORTANT NOTICES

**Trailerable ONLY with a FULL Front windshield AND Roof - or damage can occur!
Due to extreme wind turbulence, towing on an open trailer pulled by a motor home, bus or other large size vehicle at highway speeds is NOT recommended.**

CAUTION

Limited Towing at lower speeds (60mph or less) for shorter distances is acceptable with a FULL Front Windshield AND Roof ONLY. Prolonged towing at highway speeds on an Open trailer is NOT recommended and can cause damage that is NOT covered under Warranty. Whenever towing anytime, it is mandatory to check all windshield hardware BEFORE towing and at frequent intervals afterwards!

SPIKE suggests removal of Rear Windshields if towed in any conditions that are NOT recommended - removal will also create less drag on the tow vehicle

2. Maintenance and Care

Tighten all hardware after first use and periodically thereafter.

See cleaning instructions on following page.

Cleaning Instructions for Polycarbonate Products

General Purpose Polycarbonate Products-GP will mar easily with wiping action. To minimize the risk of damage, use only compatible cleaners, a soft, clean cloth, (no paper towels!) and follow proper cleaning procedure as outlined below.

Hard coated Polycarbonate Products-HC offer a higher degree of both surface hardness and abrasion resistance, providing superior protection against unintentional chemical attack/damage. However, the use of abrasive, gritty cleaners or aggressive cleaning should be avoided to eliminate the possibility of scratching or damaging the coating. PLEASE NOTE: Trailing on an open trailer can cause windshield damage due to anti-freeze, brake fluid, oil, gasoline and even battery acid from other vehicles.

Cleaning / Preventing Scratches-ALL Shields:

- Pre-rinse the polycarbonate product with water to loosen and remove surface residue, grit and grime thoroughly. Pressure-washer spray is fine but at a safe distance with a fan spray nozzle – not jet spray mode.
- Using a clean sponge, microfiber sponge or soft cloth gently wash the polycarbonate product with lukewarm water. While cleaning - Keep the sponge clean of dirt, grit and debris. Rinse it frequently and keep it loaded with soap suds. MILD, diluted car wash soap is acceptable. **Do not apply cleaners under direct sunlight or during high temperatures!**
- Immediately rinse thoroughly with water, **DO NOT** allow cleaners to dry on the shield!
- Thoroughly dry using pressurized air, a chamois or moist cellulose sponge to prevent water spots.
- Protect using a quality product such as Plexus plastic cleaner, Rain X Plastic (**not standard RainX**), or liquid car wax and a soft cloth. Plexus is a registered trademark of B.T.I chemical.

Compatible Cleaners for General Purpose Polycarbonate and Hard coated Polycarbonate Products:

The following cleaning agents have been found compatible with polycarbonate products. Follow the manufacturer's recommendations and instructions.

Compatible Cleaners: Joy®, Palmolive liquid®, or mild car wash soap diluted appropriately. **Do NOT use in sunlight or let dry!** Joy is a registered trademark of Procter & Gamble; Palmolive is a registered trademark of Colgate Palmolive.

Compatible Organic Solvents: Butyl Cellosolve, Kerosene, Naphtha (VM&P) grade.
Use these solvents only in extreme cases-All residual organic solvents should be removed with a second rinse.

Compatible Alcohols: Isopropyl Alcohol.
All residual organic alcohols should be removed with a second rinse.

Repairing Hairline Scratches (General Purpose Polycarbonate” Products Only):

Deep scratches and gouges made by sharp objects such as keys, screwdrivers, and knives cannot be repaired. Hairline scratches and minor abrasions may be minimized by using a buffing/ polishing compound. We suggest testing a small area of the product first using a compatible polish following the manufacturer's instructions, prior to using the polish on the entire product. **ALWAYS** use a soft cloth and **NEVER** use paper towels.

Compatible buffing compound: Novus Plastic Polish #1 & #2, Mirror Glaze Clear Plastic Polish.

Cleaning and protecting, we recommend Plexus® plastic cleaner, Rain X Plastic (**not standard RainX**) or Liquid Car Wax.
Plexus is a registered trademark of B.T.I chemical.

For HARD COATED products, buffing the surface is not recommended. Buffing scratched areas may worsen the condition and further damage the coating. Once the coating is removed, it cannot be repaired and buffing may optically distort the polycarbonate product. Quick Spot cleaning on the trail can be done with water or window cleaner such as Sparkle etc., and a soft cloth. Rain-X can be used on HC Polycarbonate but **NOT** on GP Polycarbonate.

Some Important "Do NOT's":

- **DO NOT** use abrasive or high alkaline cleaners on polycarbonate products!
- **DO NOT** scrape polycarbonate products with squeegees, razor blades or other sharp instruments.
- **DO NOT** use gasoline, benzene, acetone, or carbon tetrachloride on polycarbonate products.
- **DO NOT** clean polycarbonate products in direct sunlight or at elevated temperatures.
- **DO NOT** leave cleaners on polycarbonate products for a long period of time. Rinse **IMMEDIATELY**.
- **DO NOT** clean polycarbonate products with gasoline.
- **DO NOT** use any cleaners other than those specified on the approved and compatible list included in this guide.
- **DO NOT** use **Super glue or thread lockers such as Loctite-immediate damage to the polycarbonate will result!**