



**INSTALLATION INSTRUCTIONS
YAMAHA WOLVERINE RMAX 4
REAR TINTED WINDSHIELD - VENT
PART # 78-7504-R-T**

IMPORTANT NOTICES

READ AND UNDERSTAND THESE INSTRUCTIONS COMPLETELY BEFORE INSTALLATION TO AVOID INJURY TO YOURSELF, DAMAGE TO THE VEHICLE OR ACCESSORY.

- For proper installation, TWO people are required.
- Torque specifications must be followed when tightening bolts. Over-tightening any and/or all screws will cause cracks around mounting holes which is not covered by any warranty.
 - As specified on carton label, once protective film on shields is removed, product cannot be returned.
- As specified on carton label, damage caused by packaging staples is not covered by warranty. All staples must be removed prior to removing product from carton.
 - ANY cutting, trimming, drilling or altering of this product as delivered is not covered under warranty.
- Failure to follow these installation instructions completely may void any warrantable components and result in product damage or personal injury.
- Do not use Loctite/Super Glue or any other similar fastener adhesive. These types of products react to plastics and cause cracking. Not covered by any warranty.
 - Our windshields are made from the highest quality material providing optimum transparency and clarity. Blurriness and/or extrusion marks may or may not appear when looking through windshield from a wide, side-angle. This is normal for all extruded clear plastic materials.
- The application of improper cleaners, abrasive and/or dirty cleaning towels can severely damage the product. Failure to follow cleaning recommendation (provided herewith) may void any warrantable components.

DEALER

These instructions contain important information for future reference and must be given to the customer at time of purchase or upon completion of installation.

Parts List (parts available with kit only and not available separately)

ITEM	PART NAME	DESCRIPTION	QTY	
A	Windshield	CNC windshield cut-out made of 1/8" thick GE tinted polycarbonate or equivalent	1	
B	Co-extruded bulb seal (1/4")	Includes: 57" Co-extruded bulb seal / #77-95BS [end user to cut to exact length]	1	
C	Vent assembly	Includes: 1 vent cover, 1 vent flap assembly, 1 rubber vent seal and 7 vent mounting screws	1	
INSTRUCTION BAG	D	Flop clamp set	Includes: 2 flop clamps, 2 philips truss head screws M6 x 16 and 2 plastic shoulder washers M6	1
	E	Flop clamp set	Includes: 3 flop clamps, 3 philips truss head screws M6 x 16, 3 plastic shoulder washers M6 and 2 round clamp spacers (1 1/8" long)	1

1. Installation

- a) Find a clean flat area where you can safely lay down the windshield (Item A). Partially remove the protective film on both sides and apply the co-extruded bulb seal (Item B) using manual pressure to ensure good adhesion and cut any excess.

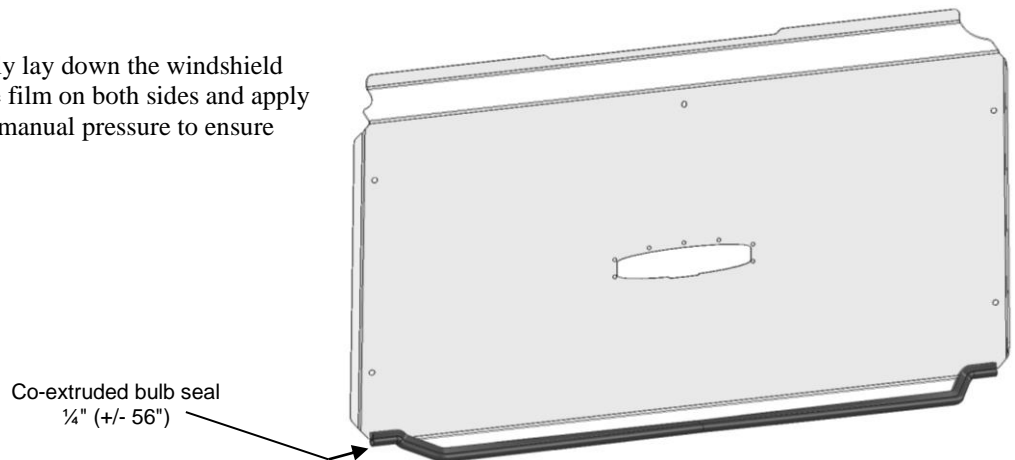

IMPORTANT NOTICES

Torque specifications must be followed when tightening bolts.

Over-tightening any and/or all screws will cause cracks around mounting holes which is not covered by any warranty.

b) **Vent assembly (Item C) installation:** Partially remove the protective film on both sides of the rear windshield (Item A) around the vent cutouts and follow instructions below.

a. From the front side (cab side) of the windshield, slide the vent flap assembly (Item C) in the vent cut out as shown in image b1. Ensure the lower tab nests into the front of the windshield as shown in image b2 & b3.

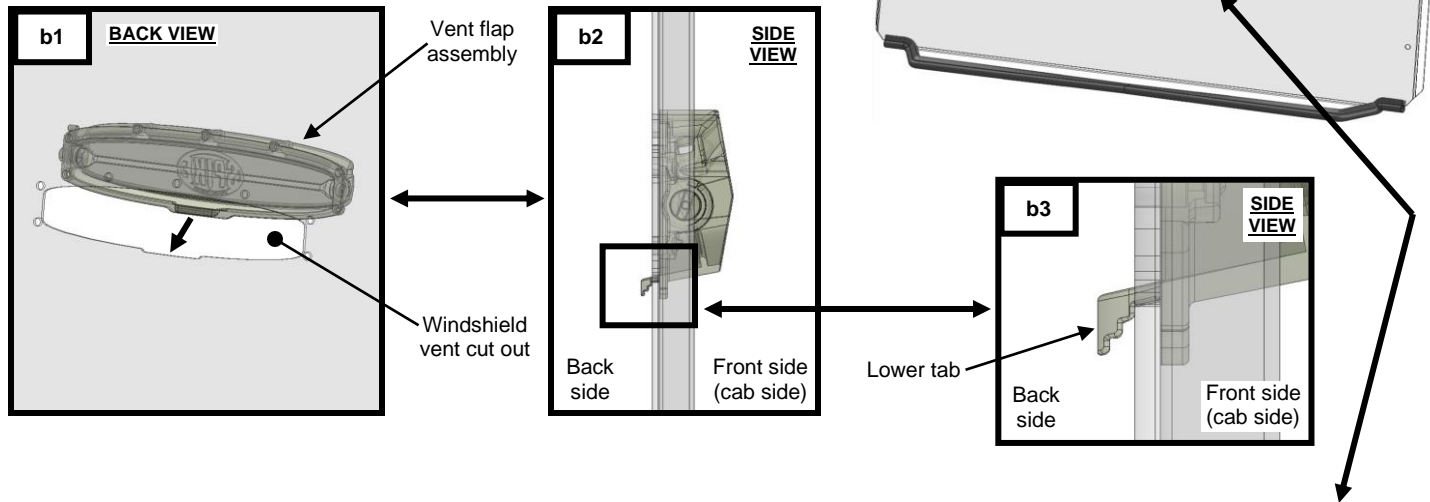

b. Install the remaining vent components (Item C) using supplied hardware as shown below in image b4 & b5.

Caution: over tightening any hardware could cause irreversible damage to the windshield.
DO NOT USE POWER TOOLS FOR THE INSTALLATION OF THE 7 MOUNTING SCREWS.

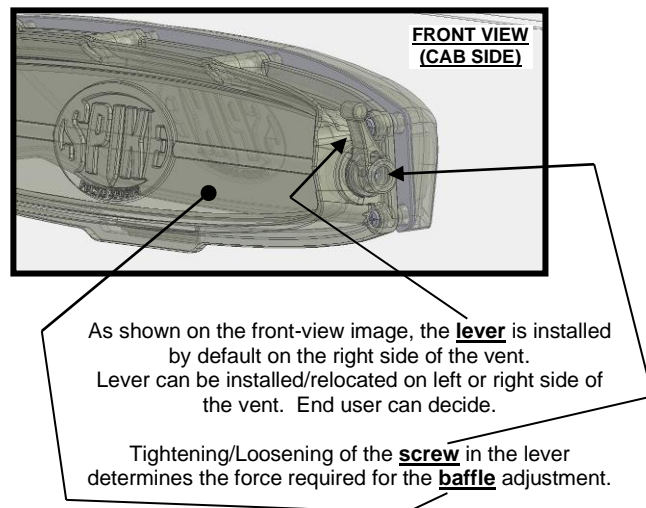
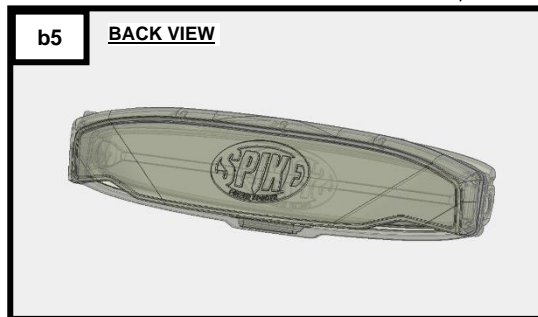
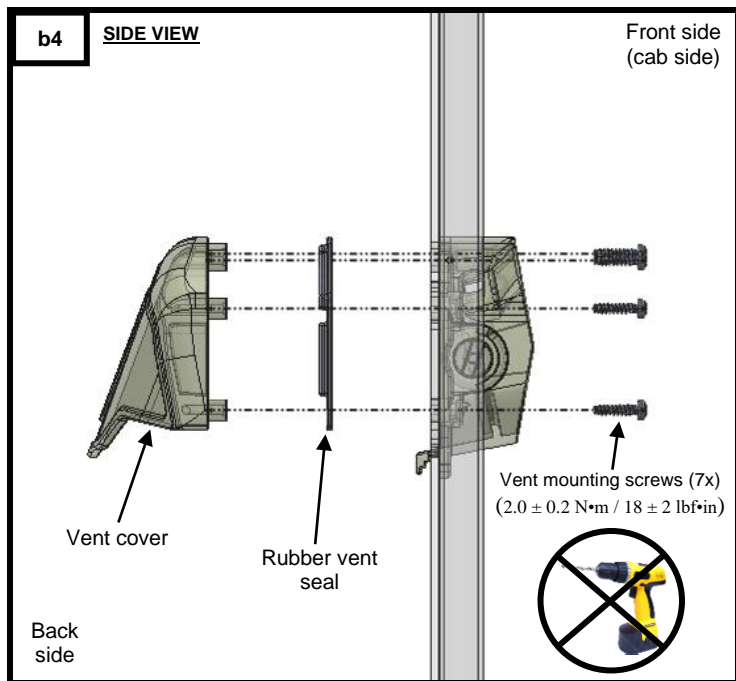

IMPORTANT NOTICES

Over-tightening any and/or all screws will cause cracks around mounting holes which is not covered by any warranty.

- c) Attach the clamps (Item D & E) to the roll-cage as shown below and pre-adjust tightening tension of all clamps. **NOTE: Keep all clamp handles open as shown in step 3 below; this will allow you to move the clamps up or down when installing the windshield for the first time.**

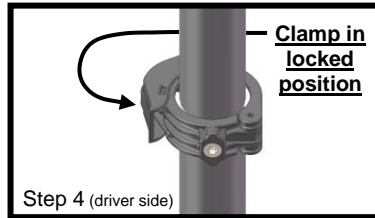
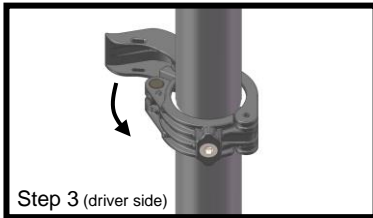
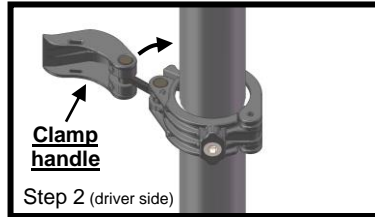
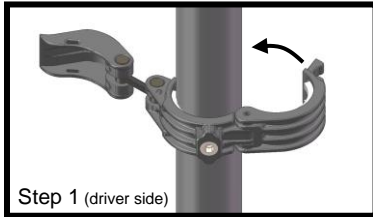

To apply more or less tension to the roll cage, simply rotate the clamp handle from the tension screw as shown below. Over tightening clamps to roll-cage could cause parts failures.

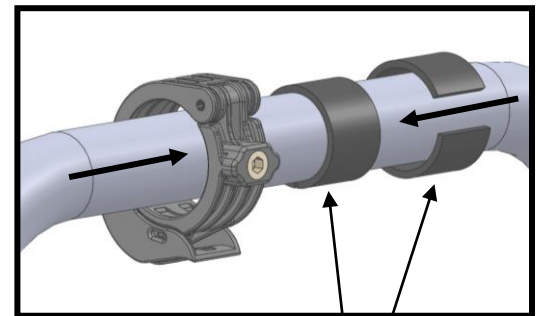
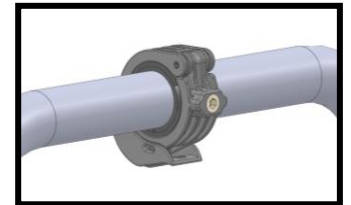
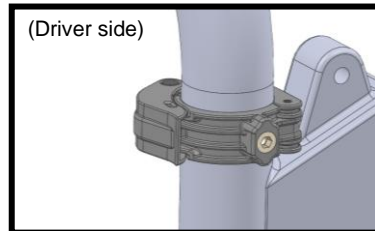
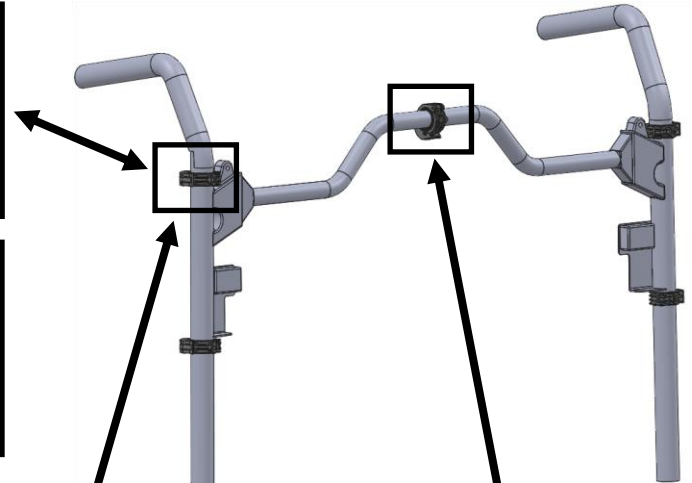
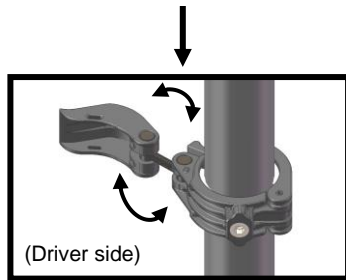

IMPORTANT NOTICES

Torque specifications must be followed when tightening bolts.

Over-tightening any and/or all screws will cause cracks around mounting holes which is not covered by any warranty.

- d) Install windshield to the clamps using supplied screws and washers without applying final torque. Ensure that the windshield and all clamps are properly positioned. Secure all clamps in locking position [Ref: Step 4 - section b] and tighten all screws as shown below.

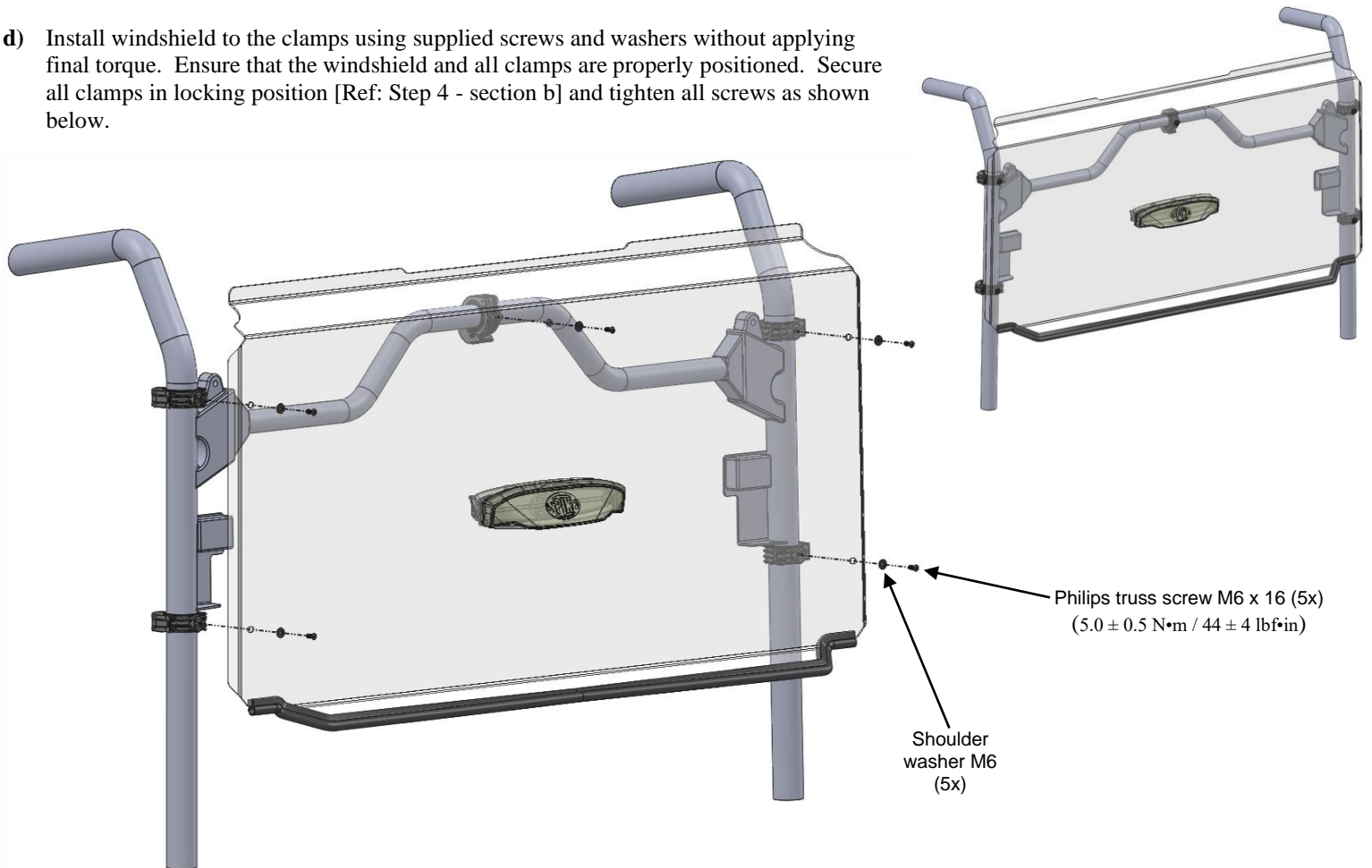

IMPORTANT NOTICES

Trailerable ONLY with a FULL Front windshield AND Roof - or damage can occur!
Due to extreme wind turbulence, towing on an open trailer pulled by a motor home, bus or other large size vehicle at highway speeds is NOT recommended.

CAUTION

Limited Towing at lower speeds (60mph or less) for shorter distances is acceptable with a FULL Front Windshield AND Roof ONLY. Prolonged towing at highway speeds on an Open trailer is NOT recommended and can cause damage that is NOT covered under Warranty. Whenever towing anytime, it is mandatory to check all windshield hardware BEFORE towing and at frequent intervals afterwards!

SPIKE suggests removal of Rear Windshields if towed in any conditions that are NOT recommended - removal will also create less drag on the tow vehicle

2. Maintenance and Care

Tighten all hardware after first use and periodically thereafter.

CLEANING:

- Rinse with lukewarm water; wash gently with mild soap or detergent and lukewarm water, using a soft cloth or sponge. **DO NOT SCRUB** or use brushes or squeegees.
 - Rinse again. Dry with soft cloth or moist cellulose sponge to prevent water spotting.
- To remove wet paint, glazing compound or grease, rub lightly with a good grade of VM&P naphtha or isopropyl alcohol, then wash and rinse. **DO NOT USE GASOLINE.**

NOTICE: Abusive cleaning procedures by hand washing or automated washing equipment will eventually result in visual hazing, loss of light transmission and coating delamination.

Compatible Cleaning Agents

- Aqueous Solution of Soaps and Detergents

----- Joy ----- Freon T.F. ----- Palmolive liquid ----- Top Job ----- VM&P grade Naphtha ----- Windex (with ammonia D) -----

MINIMIZING HAIRLINE SCRATCHES

For minimizing scratches and minor abrasions, mild automobile polish can be used.

Recommended products: Johnson Paste Wax, Novus Plastic Polish #1 and #2, Mirror Glaze plastic polish and Plexux1.

Testing polish on a separate Lexan sample is recommended. Be sure to follow product instructions carefully.