



INSTALLATION INSTRUCTIONS
POLARIS RANGER XP900/1000
FULL WINDSHIELD – DUAL VENT - TRR (Tool-less Rapid Release)
PART # 78-9810

IMPORTANT NOTICES

READ AND UNDERSTAND THESE INSTRUCTIONS COMPLETELY BEFORE INSTALLATION TO AVOID INJURY TO YOURSELF, DAMAGE TO THE VEHICLE OR ACCESSORY.

- For proper installation, **TWO** people are required.
- Torque specifications must be followed when tightening bolts. Over-tightening any and/or all screws will cause cracks around mounting holes which is not covered by any warranty.
 - As specified on carton label, once protective film on shields is removed, product cannot be returned.
- As specified on carton label, damage caused by packaging staples is not covered by warranty. All staples must be removed prior to removing product from carton.
- Failure to follow these installation instructions completely may void any warrantable components and result in product damage or personal injury.
- Do not use Loctite or any other similar fastener adhesive. These types of products react to plastics and cause cracking. Not covered by any warranty.
 - Our windshields are made from the highest quality material providing optimum transparency and clarity. Blurriness and/or extrusion marks may or may not appear when looking through windshield from a wide, side-angle. This is normal for all extruded clear plastic materials.
- The application of improper cleaners, abrasive and/or dirty cleaning towels can severely damage the product. Failure to follow cleaning recommendation (provided herewith) may void any warrantable components.

DEALER

These instructions contain important information for future reference and must be given to the customer at time of purchase or upon completion of installation.

Parts List (parts available with kit only and not available separately)

ITEM	PART NAME	DESCRIPTION	QTY
A	Windshield	CNC windshield cut-out made of 1/4" thick MR10 GE polycarbonate or equivalent	1
B	Vent assembly	Includes: 1 vent cover, 1 vent flap assembly, 1 rubber vent seal and 7 vent mounting screws	2
C	Co-extruded SIDE bulb seal (1/4")	Includes: 159" Co-extruded SIDE bulb seal (1/4") / #77-95BS-SIDE [end user to cut to exact length]	1
INSTRUCTION BAG	D TRR clamp set (profile cage)	Includes: 4 TRR (Tool-less Rapid Release) windshield hooks, 4 TRR cage clamps and 4 TRR (Tool-less Rapid Release) SPIKE covers	1

1. Installation

- a) Find a clean flat area where you can safely lay down the windshield (Item A). Partially remove the protective film on both sides and apply the co-extruded **SIDE** bulb seal (Item C) starting at bottom center of the windshield using manual pressure to ensure it is properly and fully seated.

At the start/finish of the **SIDE** bulb seal, cut an extra 1/4" more than required. This will ensure a tight fit between the start and finish of the bulb seal.

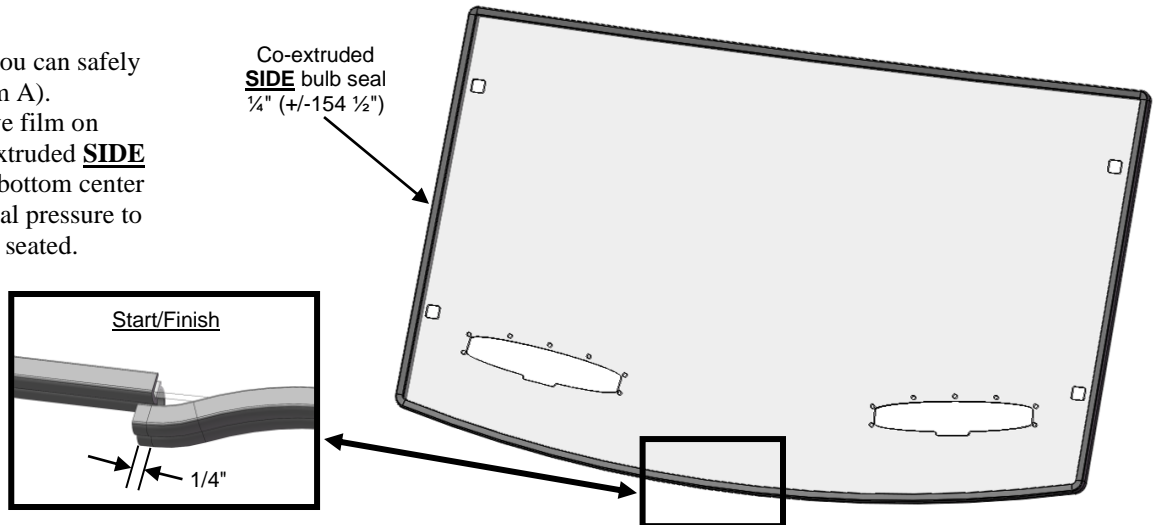

IMPORTANT NOTICES

Torque specifications must be followed when tightening bolts.

Over-tightening any and/or all screws will cause cracks around mounting holes which is not covered by any warranty.

b) Vent assembly (Item B) installation: Partially remove the protective film on both sides of the windshield around the vent cutouts and follow instructions below. (Left vent / Driver side installation is shown below)

- From the back side of the windshield, slide the vent flap assembly in the vent cut out as shown in image b1. Ensure the lower tab nests into the front of the windshield as shown in image b2 & b3.

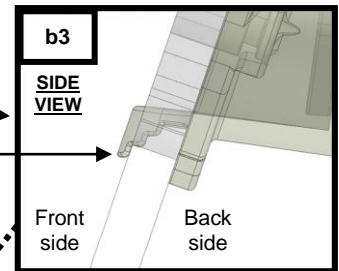
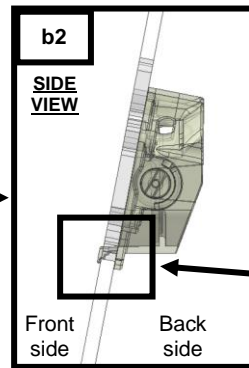
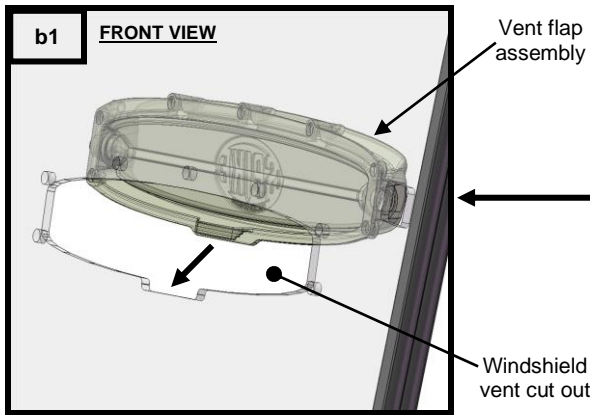
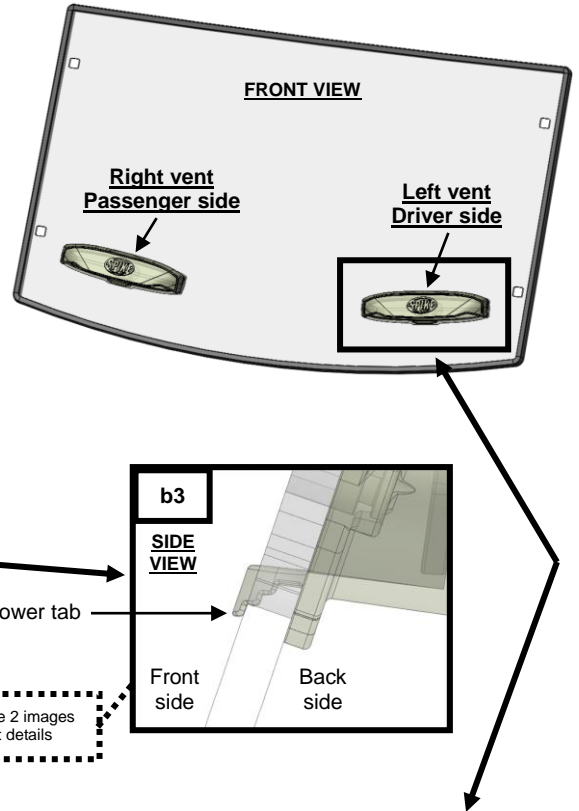

SIDE bulb seal is not shown on these 2 images to properly show the vent's mount details

- Install the remaining vent components (Item B) using supplied hardware as shown below in image b4 & b5.

Caution: over tightening any hardware could cause irreversible damage to the windshield.
DO NOT USE POWER TOOLS FOR THE INSTALLATION OF THE 7 MOUNTING SCREWS.

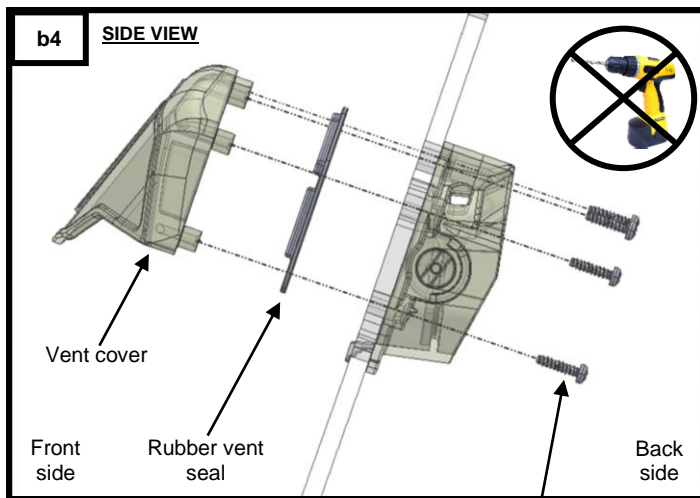
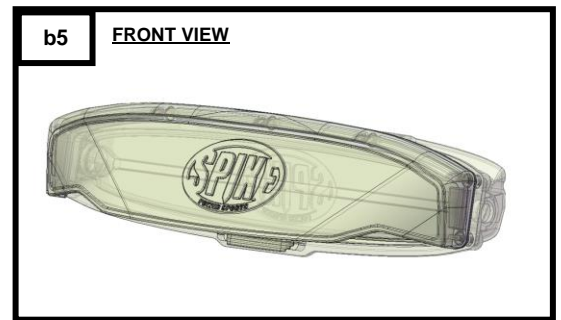

Vent mounting screws (7x)
 (2.0 ± 0.2 N•m / 18 ± 2 lbf•in)

SIDE bulb seal is not shown on this image to properly show the vent's mount details

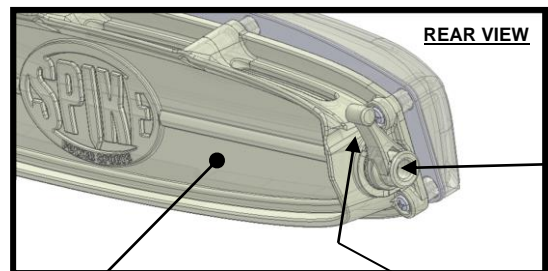

As shown on the rear-view image, the **lever** is installed by default on the right side of the vent. Lever can be installed/relocated on left or right side of the vent. End user can decide.

Tightening/Loosening of the **screw** in the lever determines the force required for the **baffle** adjustment.

- c) Partially remove the protective film on both sides around the windshield square holes (4) and install the TRR clamps (Item D) on the windshield as shown below. (Left / Driver side installation shown below)

1. From the front side of the windshield, slide the TRR windshield hook through the windshield square holes as shown in image c1.

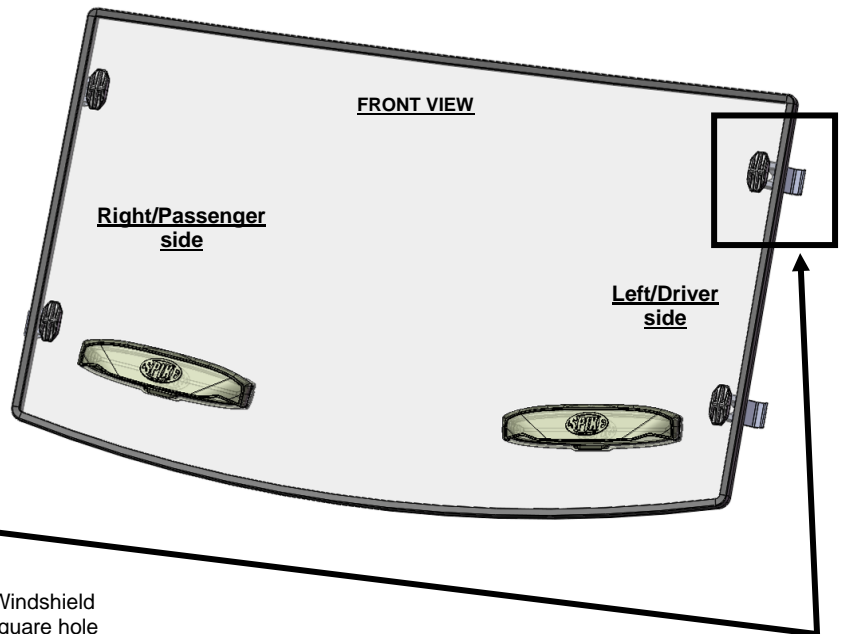
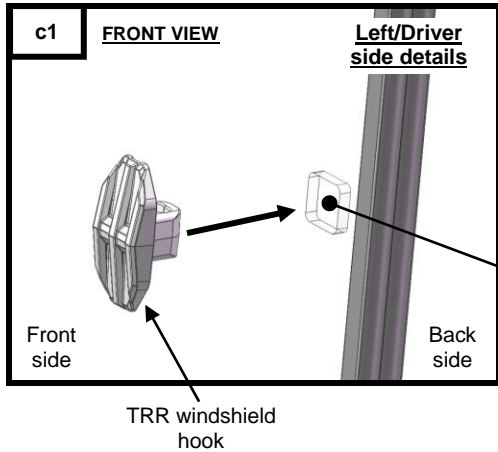

2. From the back side, snap the TRR cage clamp to the TRR windshield hook as shown in image c2 & c3. These parts are designed as a tight-fit and require some force to properly snap together. When properly installed, they will not come off. See diagrams below for proper installation example.

TRR cage clamps should not come off easily during installation. If so, repeat this step until proper fit is achieved. They will not come off when properly installed.

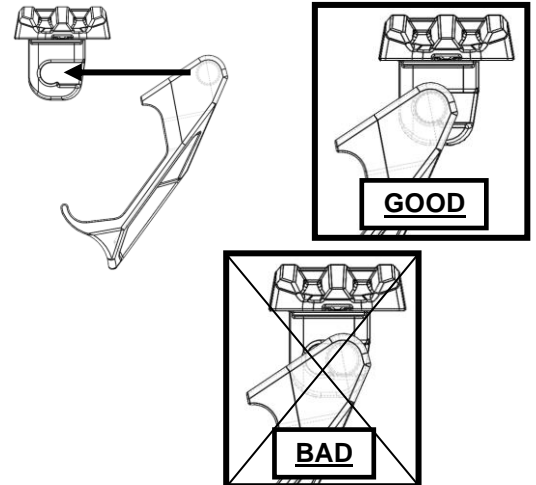
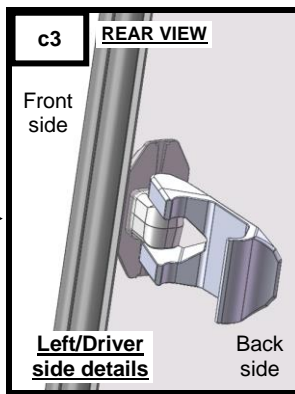
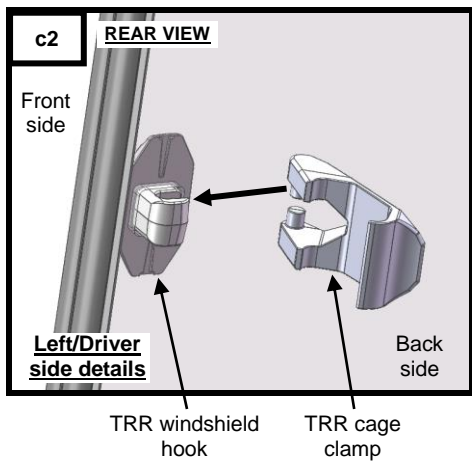

3. From the front side, press-fit the TRR SPIKE covers (Item D) to each TRR windshield hook as shown in image c4 & c5.

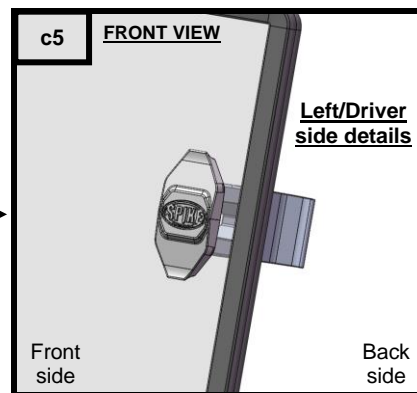
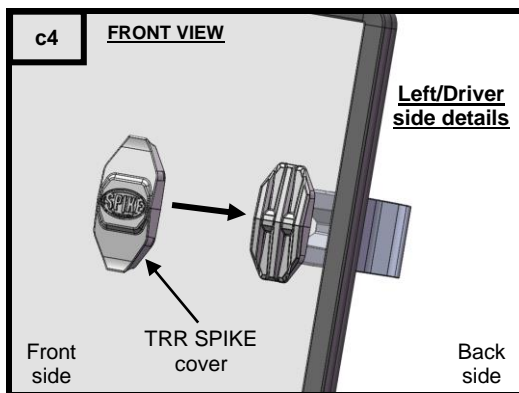

- d) Install and secure the assembled windshield to the vehicle by rotating/snapping the TRR cage clamps to the vehicle roll bar cage as shown in images d1 & d2 & d3. Adequate force is required to rotate/snap the clamp to the roll bar.

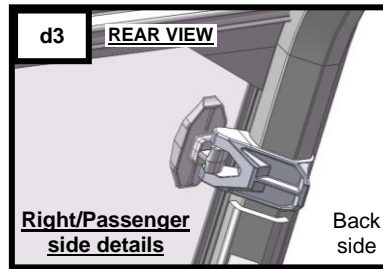
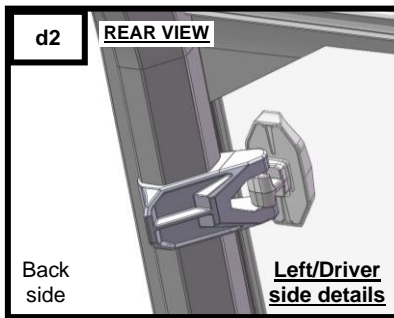
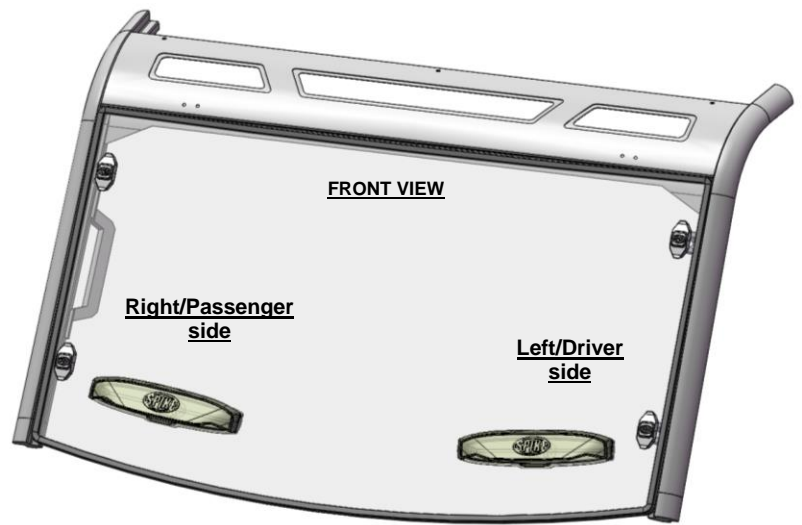
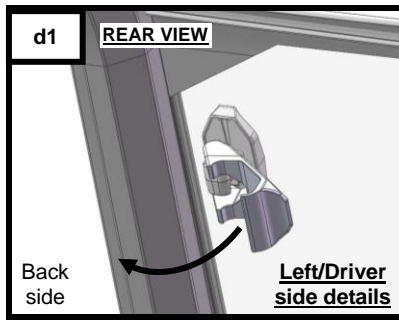

WARNING

TRR clamps must be properly installed. If not, the windshield will not be properly secured to the vehicle and may fly off when riding/towing. Serious injury may occur.

CAUTION

Please understand that open trailer towing can result in windshield/roof damage due to high wind pressure and road debris. Towing at Highway Speeds (75+ mph) for EXTENDED periods (over 100 miles) causes constant and extreme pressure at the mount areas, and is not recommended. Spike suggests removal of roofs/windshields if towed in these conditions-removal will also create less drag on the tow vehicle. Lower speeds (60 mph) or two-lane roads are no problem.

CAUTION

NEVER trailer your vehicle oriented backwards with a full front windshield in place. Windshield could break away.

ALWAYS trailer your vehicle facing forward.



2. Maintenance and Care

Tighten all hardware after first use and periodically thereafter.

CLEANING:

- Rinse with lukewarm water; wash gently with mild soap or detergent and lukewarm water, using a soft cloth or sponge. **DO NOT SCRUB** or use brushes or squeegees.
 - Rinse again. Dry with soft cloth or moist cellulose sponge to prevent water spotting.
- To remove wet paint, glazing compound or grease, rub lightly with a good grade of VM&P naphtha or isopropyl alcohol, then wash and rinse. **DO NOT USE GASOLINE.**

NOTICE: Abusive cleaning procedures by hand washing or automated washing equipment will eventually result in visual hazing, loss of light transmission and coating delamination.

Compatible Cleaning Agents

- Aqueous Solution of Soaps and Detergents

Fantastik	Joy	Formula 409	Mr. Clean	Top Job	VM&P grade Naphtha	Hexcel, F.O. 554	Neleco-Placer
-----------	-----	-------------	-----------	---------	--------------------	------------------	---------------