



**INSTALLATION INSTRUCTIONS
POLARIS RANGER CREW MID-SIZE 2015
ROOF
PART # 88-5720**

IMPORTANT NOTICES

READ AND UNDERSTAND THESE INSTRUCTIONS COMPLETELY BEFORE INSTALLATION TO AVOID INJURY TO YOURSELF, DAMAGE TO THE VEHICLE OR ACCESSORY.

- For proper installation, TWO people are required.
- Torque specifications must be followed when tightening bolts. Over-tightening any and/or all screws will cause cracks around mounting holes which is not covered by any warranty.
- As specified on carton label, damage caused by packaging staples is not covered by warranty. All staples must be removed prior to removing product from carton.
- Failure to follow these installation instructions completely may void any warrantable components and result in product damage or personal injury.
- Do not use Loctite or any other similar fastener adhesive. These types of products react to plastics and cause cracking. Not covered by any warranty.

DEALER

These instructions contain important information for future reference and must be given to the customer at time of purchase or upon completion of installation.

Parts List (parts available with kit only and not available separately)

ITEM	PART NAME	DESCRIPTION	QTY
A	Front roof	Front roof made of 3/16" thick high density polyethylene	1
B	Rear roof	Rear roof made of 3/16" thick high density polyethylene	1
C	Co-extruded bulb seal	Includes: 228" Co-extruded bulb seal [end user to cut to exact length]	1
INSTRUCTION BAG	D	Foam cushion Included: 132" of 1" x 1/8" self adhesive foam cushion [end user to cut to exact length]	1
	E	Foam cushion Included: 48" of 1" x 1/16" self adhesive foam cushion [end user to cut to exact length]	1
	F	Nuts & bolts Includes: 8 metal plate hooks, 17 philips truss head screws M6 x 20, 3 philips truss head screws M6 x 24, 32 plastic washers M6, 3 rubber washers M6 and 12 locknuts M6	1
	G	Wet-nap Includes: wet-nap	2

1. Installation

- a) Apply the self-adhesive foam cushion (Item D) to the back side of the front roof (Item A) as shown. For proper installation, the roof must be free of any dust or any other contamination. Use the roof's side edge notches as guides to position and align the foam cushion as shown below. You must leave a free gap of 3/4" from side edges.

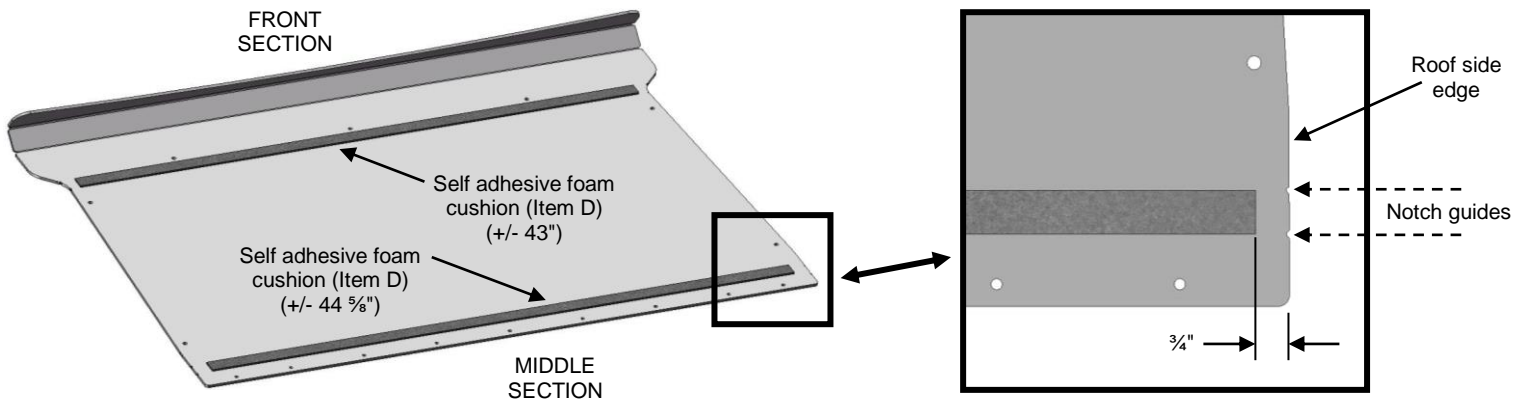

IMPORTANT NOTICES

Over-tightening any and/or all screws will cause cracks around mounting holes which is not covered by any warranty.

- b) Apply the self-adhesive foam cushion (Item D) to the back side of the rear roof (Item B) as shown. For proper installation, the roof must be free of any dust or any other contamination. Use the roof's side edge notches as guides to position and align the foam cushion as shown below. You must leave a free gap of $\frac{3}{4}$ " from side edges.

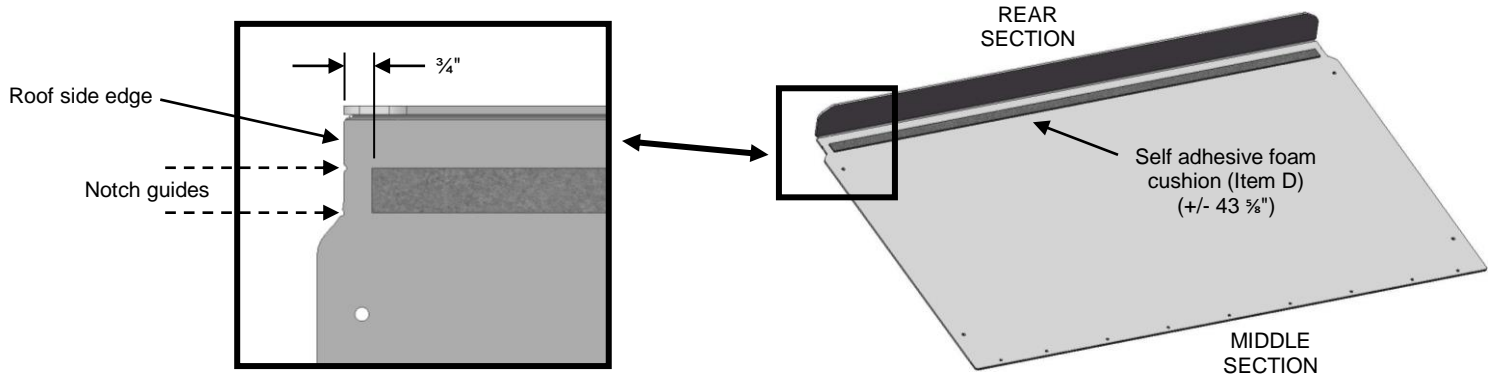

- c) Apply the self-adhesive foam cushion (Item E) to the front side of the rear roof (Item B) as shown. For proper installation, the roof must be free of any dust or any other contamination. Using a pen, screwdriver or any other similar pointy tool, pierce through the foam cushion using the rear roof mounting holes as guides (9 locations).

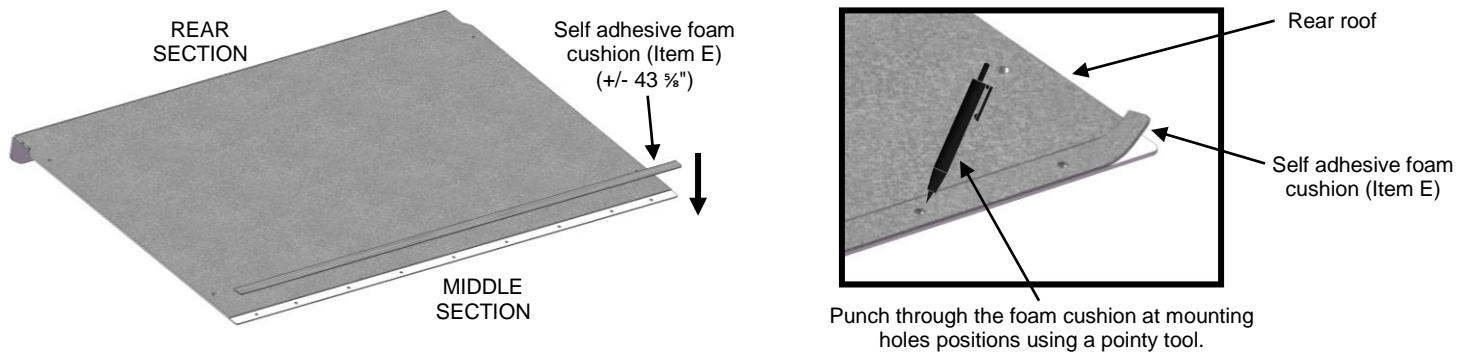

- d) Assemble the front and the rear roof together using supplied hardware (Item F) as shown below.

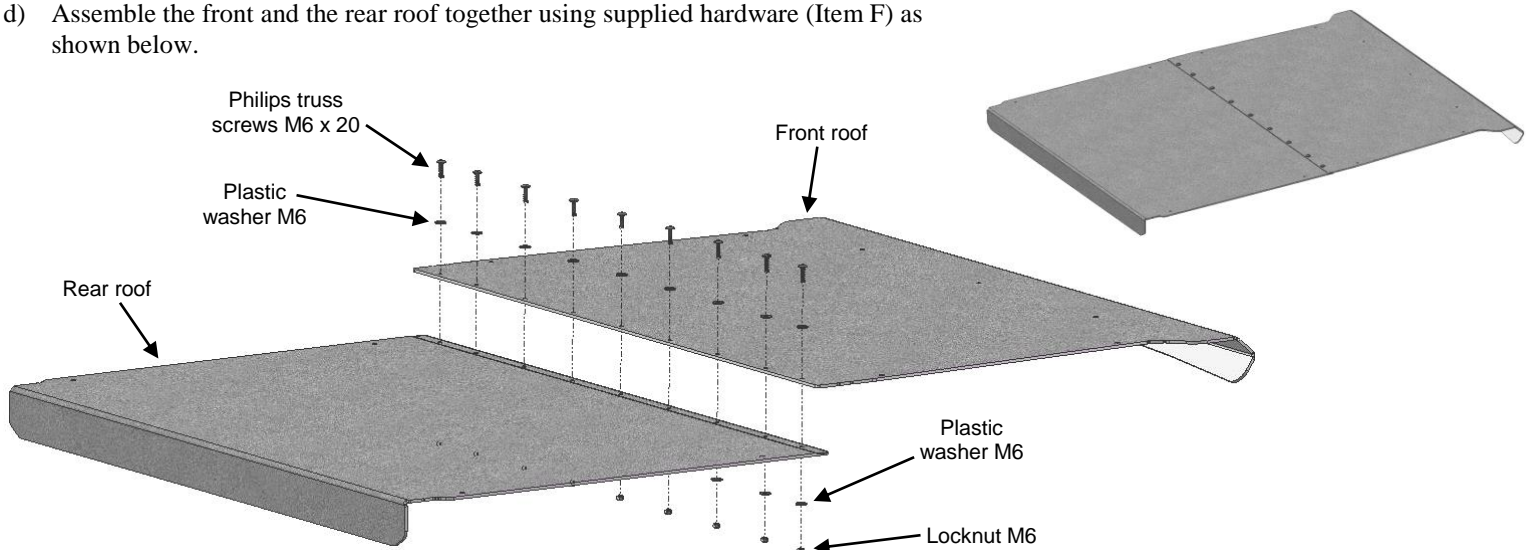

IMPORTANT NOTICES

Over-tightening any and/or all screws will cause cracks around mounting holes which is not covered by any warranty.

- e) Apply the co-extruded bulb seal (Item C) to the roof edges using manual pressure to ensure good adhesion. Before final cut, leave an extra length of 1/4" at the finishing end and cut. Extra length will ensure a tight fit. (Fig. B1)

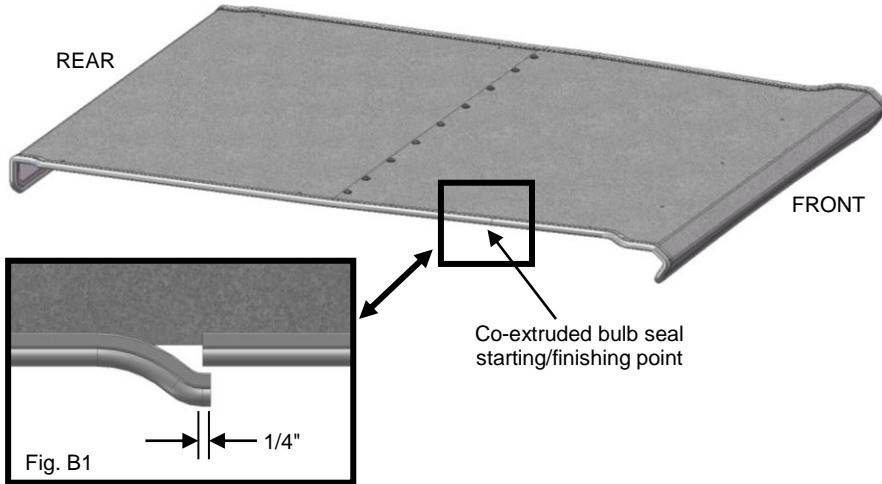

- f) Install the roof to the vehicle using supplied hardware (Item F) as shown below and tighten. Note that some sections of the roll cage are hidden for better clarity.

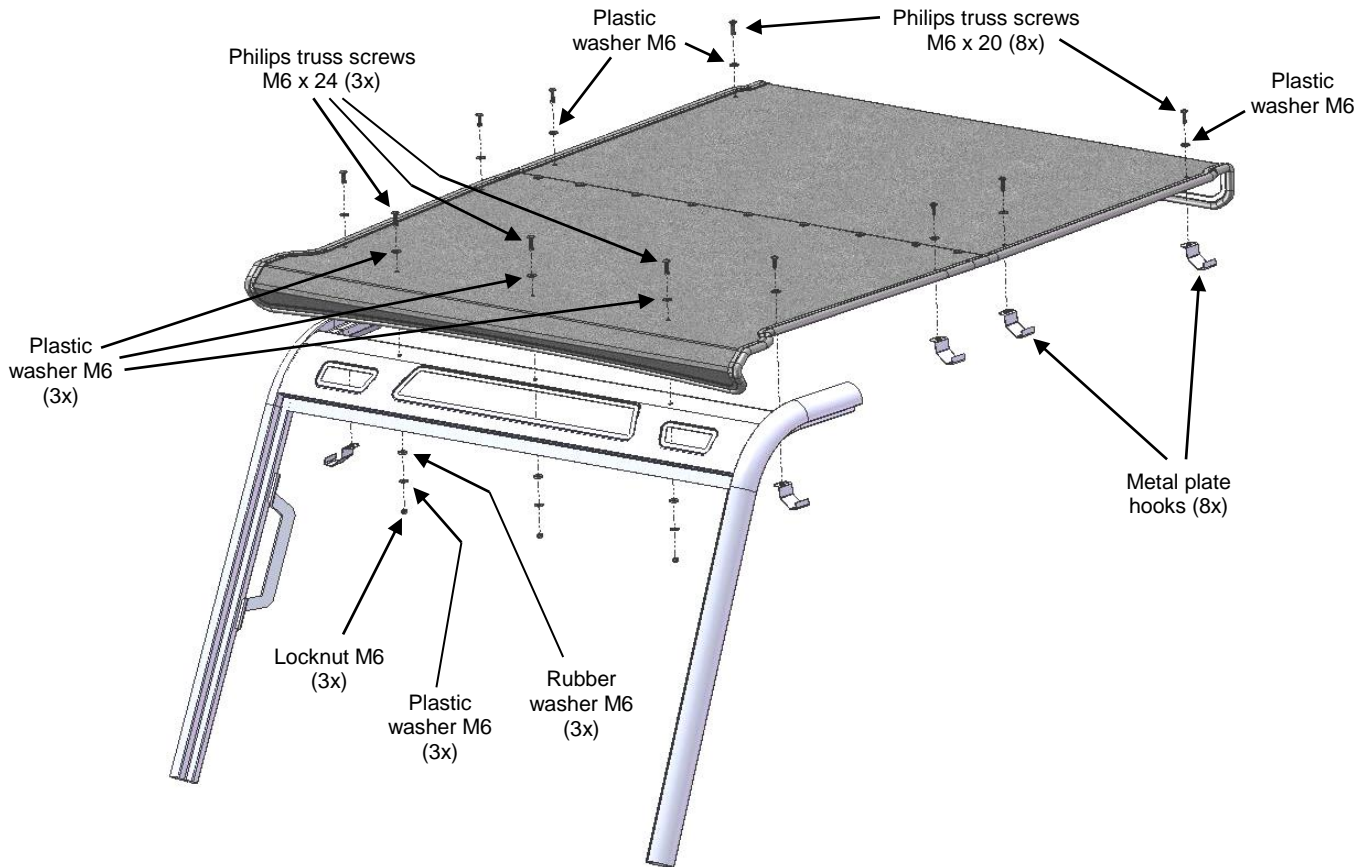

2. Maintenance and Care

Tighten all hardware after first use and periodically thereafter.